



# BESEL S.A.

## FABRYKA SILNIKÓW ELEKTRYCZNYCH

### SILNIKI O NISKIM WZNIOSIE OSI WAŁU 65 mm

1-fazowe i 3-fazowe serii "h" i "hR" do maszyn do drewna

#### Charakterystyka silnika:

- znajdują zastosowanie głównie w maszynach do drewna,
- praca ciągła S1 lub przerywana S6 (40% 60c/h)
- napięcia znamionowe 230V (1-fazowe), 400V (3-fazowe)
- częstotliwość zasilania 50 Hz,
- stopień ochrony IP 54,
- klasa izolacji F,
- kadłub z rury ciągnionej profilowej, tarcze żeliwne (seria "hR"), kadłub oblewany (seria "h"),
- silniki mogą być wykonywane z dowolną końcówką wałka, z uchwyconym łożyskiem od strony napędu (bez luzu poosiowego).



### MOTORS WITH SHAFT HEIGHT 65 mm

1- and 3-phase motors for woodworking machines series "h" and "hR"

#### Description of the catalogue motors:

- general used in woodworking machines,
- continuous duty S1 or intermittent duty S6 (40%),
- rated voltage 230V (1-phase), 400V (3-phase),
- frequency 50 Hz,
- degree of protection IP 54,
- insulation class F,
- body made of drawn section pipe, cast iron bearing shields (series "hR"),
- cast body (series "h"),
- motors can be manufactured with different end shaft, with fixed bearing at the drive end (without axial play).

Typ silnika 3-fazowego	Praca ciągła S1 (continuous duty S1)					Praca przerywana S6 - 40% (intermittent duty S6)					Masa [kg]
	Moc [kW]	Prędkość obrotowa [min <sup>-1</sup> ]	Prąd przy 400V [A]	Moment rozruchowy Mr [Nm]	Krotność prądu rozruchowego Ir/IN	Moc [kW]	Prędkość obrotowa [min <sup>-1</sup> ]	Prąd przy 400V [A]	Moment rozruchowy Mr [Nm]	Krotność prądu rozruchowego Ir/IN	
Frame size 3-phase motors	Rated output [kW]	Rated speed [min <sup>-1</sup> ]	Rated current at 400 V [A]	Torque TN [Nm]	Starting current/ rated current I <sub>L</sub> /I <sub>N</sub>	Rated output [kW]	Rated speed [min <sup>-1</sup> ]	Rated current at 400 V [A]	Torque TN [Nm]	Starting current/ rated current I <sub>L</sub> /I <sub>N</sub>	Motor weight [kg]
Sh 65-2A	0,75	2760	1,9	5,2	4,5	1,1	2670	2,8	6,3	3,1	10,0
Sh 65-2B	1,10	2760	2,5	8,0	5,0	1,5	2650	3,6	8,6	3,5	11,5
Sh 65-2C	1,50	2800	3,4	13,3	5,0	2,2	2800	5,0	12,7	3,4	13,0
Sh 65-2D	2,20	2820	4,9	25,3	5,7	3,0	2720	6,8	24,1	4,0	14,5
ShR 65-2A	0,75	2760	1,9	5,2	4,5	1,1	2670	2,8	6,3	3,1	10,0
ShR 65-2B	1,10	2760	2,5	8,0	5,0	1,5	2650	3,6	8,6	3,5	11,5
ShR 65-2C	1,50	2800	3,4	13,3	5,0	2,2	2800	5,0	12,7	3,4	13,0
ShR 65-2D	2,20	2820	4,9	25,3	5,7	3,0	2720	6,8	24,1	4,0	14,5

Typ silnika 1-fazowego	Praca ciągła S1 (continuous duty S1)					Praca przerywana S6 - 40% (intermittent duty S6)					Kondensator pracy [µF] 450V	Masa [kg]
	Moc [kW]	Prędkość obrotowa [min <sup>-1</sup> ]	Prąd przy 230V [A]	Moment rozruchowy Mr [Nm]	Krotność prądu rozruchowego Ir/IN	Moc [kW]	Prędkość obrotowa [min <sup>-1</sup> ]	Prąd przy 230V [A]	Moment rozruchowy Mr [Nm]	Krotność prądu rozruchowego Ir/IN		
Frame size 1-phase motors	Rated output [kW]	Rated speed [min <sup>-1</sup> ]	Rated current at 230 V [A]	Torque TN [Nm]	Starting current/ rated current I <sub>L</sub> /I <sub>N</sub>	Rated output [kW]	Rated speed [min <sup>-1</sup> ]	Rated current at 230 V [A]	Torque TN [Nm]	Starting current/ rated current I <sub>L</sub> /I <sub>N</sub>	Run capacitor [µF] 450V	Motor weight [kg]
SEh 65-2A	0,75	2820	5,2	1,5	3,7	1,1	2750	7,6	1,7	3,2	25	10,0
SEh 65-2B	1,10	2810	7,0	1,5	3,2	1,5	2750	10,0	1,9	2,6	30	12,0
SEh 65-2C	1,50	2800	9,5	2,6	3,4	2,2	2800	14,0	3,0	2,0	40	13,5
SEh 65-2D	2,00	2800	12,2	2,4	3,5	2,5	2700	16,0	2,4	2,7	50	15,0
SEhR 65-2A	0,75	2820	5,2	1,5	3,7	1,1	2750	7,6	1,7	3,2	25	10,0
SEhR 65-2B	1,10	2810	7,0	1,5	3,2	1,5	2750	10,0	1,9	2,6	30	12,0
SEhR 65-2C	1,50	2800	9,5	2,6	3,4	2,2	2800	14,0	3,0	2,0	40	13,5
SEhR 65-2D	2,00	2800	12,2	2,4	3,5	2,5	2700	16,0	2,4	2,7	50	15,0

Silniki mogą być wyposażone w:

- hamulce elektromagnetyczne sprężynowe (miękkie) prądu stałego - H17,
- wyłączniki realizujące funkcję: zabezpieczenia przeciążeniowego, zabezpieczenia ponadnapięciowego, wyłącznika "załącz - wyłącz", gniazda 3-, 4- i 5-bolcowe (L1, L2, L3, N, PE), wtyki 4-bolcowe i 5-bolcowe (L1, L2, L3, N, PE) wg systemu CEE7 (zewnętrzne styki zerujące),
- kołnierze zaciskowe do mocowania pól tarczowych,
- inne na życzenia Klienta.

Wszystkie silniki posiadają znak CE.

Motors can be equipped with:

- direct current electromagnetic spring-loaded brakes (soft) - H17,
- switches with the following functions: overload protection, overvoltage protection, on-off switch,
- 3, 4 and 5 pin sockets (L1, L2, L3, N, PE),
- 4 and 5 pin plugs (L1, L2, L3, N, PE) in accordance with CEE7 (external neutral pins),
- clip flanges for assembly of circular,
- other on request.

All motors are provided with CE mark.

**Silniki serii h**  
Motors series h

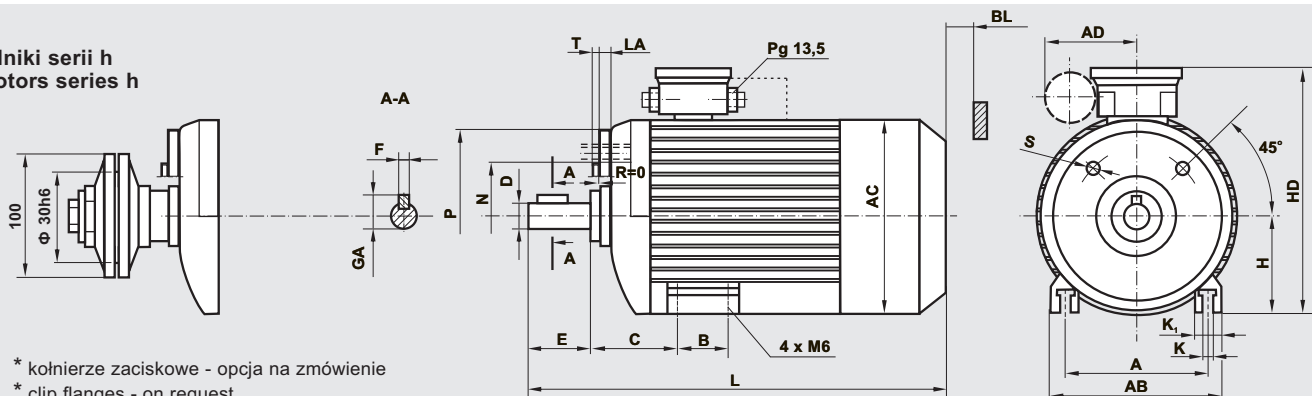

\* kołnierze zaciskowe - opcja na zamówienie  
\* clip flanges - on request

**Silniki na łapach (Foot - mounted motors)**

Typ	Wymiary (mm)														Dimensions (mm)			Łożyska Bearings
	A	B	C	D	E	F	GA	H	K	K <sub>1</sub>	AB	AC	AD	BL	HD	L		
Sh 65-2A	80	44	67	22j6	50	8	25	65 <sub>0,5</sub>	6,4	10,4	100	143,3	~85	15	~175	262	6205 2RS	
SEh 65-2A																267		
Sh 65-2B																279		
SEh 65-2B																287		
S(E)h 65-2C																309		
S(E)h 65-2D																327		

**Silniki kołnierzowe (Flange - mounted motors)**

Typ	Wymiary (mm)													Dimensions (mm)				Łożyska Bearings
	P	M	N	S	C	D	E	F	GA	LA	T	R	AC	AD	BL	L		
SKh 65-2A2	120	100	80j6	4XM6	67	22j6	50	8	25	12	3	0	143,3	~85	15	262	6205 2RS	
SEKh 65-2A2																267		
SKh 65-2B2																279		
SEKh 65-2B2																287		
S(E)Kh 65-2C2																309		
S(E)Kh 65-2D2																327		

**Silniki serii hR**  
Motors series hR

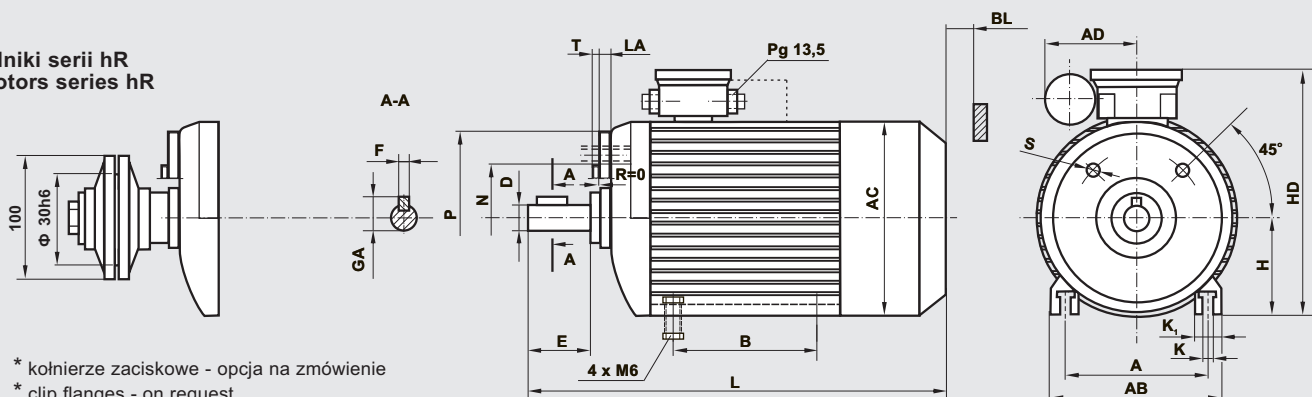

\* kołnierze zaciskowe - opcja na zamówienie  
\* clip flanges - on request

**Silniki na łapach (Foot - mounted motors)**

Typ	Wymiary (mm)														Dimensions (mm)			Łożyska Bearings
	A	B	C	D	E	F	GA	H	K	K <sub>1</sub>	AB	AC	AD	BL	HD	L		
ShR 65-2A	80	~120	-	22j6	50	8	25	65 <sub>0,5</sub>	6,4	10,4	100	143,3	~85	15	~175	272	6205 2RS	
ShR 65-2A		~125														277		
ShR 65-2B		~137														289		
SEhR 65-2B		~145														297		
S(E)hR 65-2C		~167														319		
S(E)hR 65-2D		~185														337		

**Silniki kołnierzowe (Flange - mounted motors)**

Typ	Wymiary (mm)													Dimensions (mm)				Łożyska Bearings
	P	M	N	S	C	D	E	F	GA	LA	T	R	AC	AD	BL	L		
SKhR 65-2A2	120	100	80j6	4XM6	-	22j6	50	8	25	12	3	0	143,3	~85	15	272	6205 2RS	
SEKhR 65-2A2																277		
SKhR 65-2B2																289		
SEKhR 65-2B2																297		
S(E)KhR 65-2C2																319		
S(E)KhR 65-2D2																337		

Silniki mogą być mocowane za pomocą otworów w tarczy kołnierzowej lub otworów teowych w kadłubie.

Motors fastened with the use of holes in flange plate or T-shaped holes in a body.

Producent zastrzega sobie możliwość zmian danych zawartych w karcie katalogowej wynikających z ciągłego doskonalenia wyrobu.

As part of our development program, we reserve the right to alter or amend any of the specifications without giving prior notice.