



BESEL S.A.

FABRYKA SILNIKÓW ELEKTRYCZNYCH

SILNIKI INDUKCYJNE TRÓJFAZOWE O WZNIOSIE OSI WAŁU 56

Charakterystyka silników katalogowych:

- silniki ogólnego przeznaczenia do pracy w warunkach klimatu umiarkowanego,
- praca ciągła S1,
- napięcia znamionowe 230V/400V (Δ/Y),
- częstotliwość zasilania 50 Hz,
- temperatura otoczenia od -15°C do $+40^{\circ}\text{C}$,
- kolor malowania RAL 5010.

THREE-PHASE INDUCTION MOTORS FRAME SIZE 56

Description of the catalogue motors:

- general purpose motors; temperate climate,
- duty S1,
- rated voltage 230V/400V (Δ/Y),
- frequency 50 Hz,
- ambient temperature from -15°C to $+40^{\circ}\text{C}$,
- standard paint colour RAL 5010.



stopień ochrony: IP54 (IP55; IP56; IP 65; IP 66)
klasa izolacji F (klasa H na życzenie)

degree of protection: IP54 (IP55; IP56; IP 65; IP 66)
insulation class F (class H on request)

Typ	Moc		Prędkość obrotowa [min ⁻¹]	Prąd [A] przy		Sprawność η [%]	Współ- czynnik mocy $\cos \varphi_N$	Moment znamio- nowy M_N [Nm]	Krotność prądu rozrucho- wego I_r/I_N	Krotność momentu rozrucho- wego M_r/M_N	$\frac{M_{max}}{M_N}$	Moment bezwładności J [kgm ²]	Masa [kg]
	[kW]	[KM]		230 V Δ	400 V Y								
Frame size	Rated output		Rated speed [min ⁻¹]	Rated current [A] at		Efficiency η [%]	Power factor $\cos \varphi_N$	Torque T_N [Nm]	Starting current/ rated current I_L/I_N	Starting torque/ rated torque T_L/T_N	$\frac{T_b}{T_N}$	Moment of inertia J [kgm ²]	Motor weight [kg]
	[kW]	[HP]		230 V Δ	400 V Y								

Silniki 2-biegunowe, 3000 min⁻¹; 50Hz

2-pole motors, 3000 min⁻¹; 50Hz

Sg 56-2A	0,09	0,12	2800	0,58	0,33	60	0,65	0,31	3,7	2,3	2,4	0,000076	2,9
Sg 56-2B	0,12	0,17	2800	0,62	0,36	65	0,75	0,41	3,8	1,8	2,1	0,000095	3,2

Silniki 4-biegunowe, 1500 min⁻¹; 50Hz

4-pole motors, 1500 min⁻¹; 50Hz

Sg 56-4A	0,06	0,08	1400	0,43	0,25	55	0,66	0,41	3,3	1,8	2,0	0,000145	2,6
Sg 56-4B	0,09	0,12	1380	0,59	0,34	61	0,65	0,62	3,2	1,9	2,0	0,000186	2,9

Silniki 6-biegunowe, 1000 min⁻¹; 50Hz

6-pole motors, 1000 min⁻¹; 50Hz

Sg 56-6B	0,06	0,08	900	0,60	0,35	40	0,65	0,64	1,8	1,5	1,6	0,000186	3,4
----------	------	------	-----	------	------	----	------	------	-----	-----	-----	----------	-----

Silniki Sg 56-4A i 4B w wersji standardowej nie posiadają przewietznika i osłony.

Silniki mogą być wykonane i certyfikowane na zgodność z wymogami normy UL 1004 lub CSA C22.2 No 100-04.

Silniki odpowiadają wymaganiom Polskiej Normy PN-EN 60034-1 oraz normom międzynarodowym IEC 60034-1.

Wszystkie silniki posiadają znak CE.

Motors type Sg 56-4A and 4B in standard version are without cooling fan and fan cover.

Motors may be certified for safety that they are manufactured according to the requirements of the UL 1004 or CSA C22.2 No 100-04.

Motors meet requirements of Polish Standard PN-EN 60034-1 and the international rules IEC 60034-1.

All motors are provided with CE mark.

Silniki na łapach
Forma wykonania
IMB3

Foot - mounted motors
Type of construction
IMB3

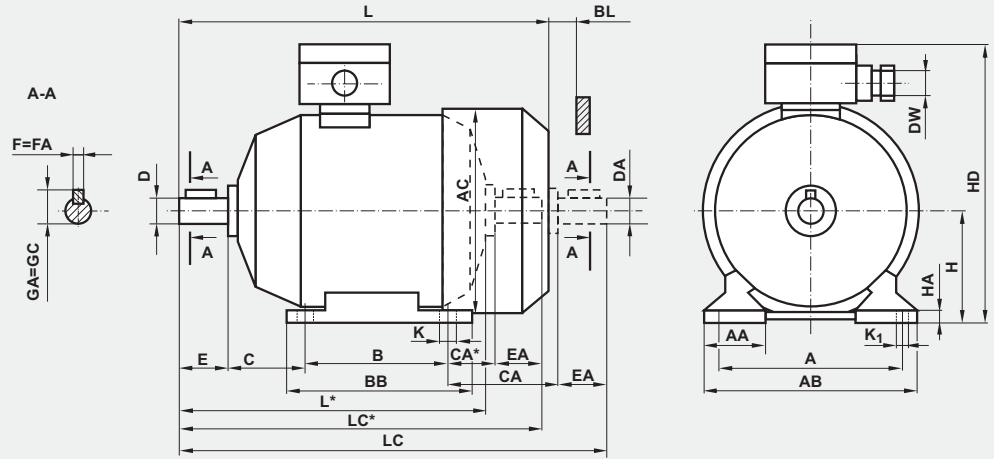

Forma wykonania IMB3

Type of construction IMB3

Typ	Wymiary (mm)																Dimensions (mm)						Łożyska Bearings
	Frame size	A	B	C	CA CA*	D=DA	E=EA	F=FA	GA=GC	H	K	K ₁	DW	AA	AB	AC	BB	BL min	HA	HD	L L*	LC LC*	
Sg 56-2A	90	71	36	74,5	9j6	20	3h9	10,2	56 _{-0,5}	5,8	8	M20	30	110	117	92	11	7	154	188	213,5	6201 2Z	
Sg 56-4A																				149*	171*		
Sg 56-2B																				196	221,5		
Sg 56-4B																				157*	179*		
Sg 56-6B																				196	221,5		

Silniki kołnierkowe
Formy wykonania
IMB5, IMB14

Flange
- mounted motors
Types of construction
IMB5, IMB14

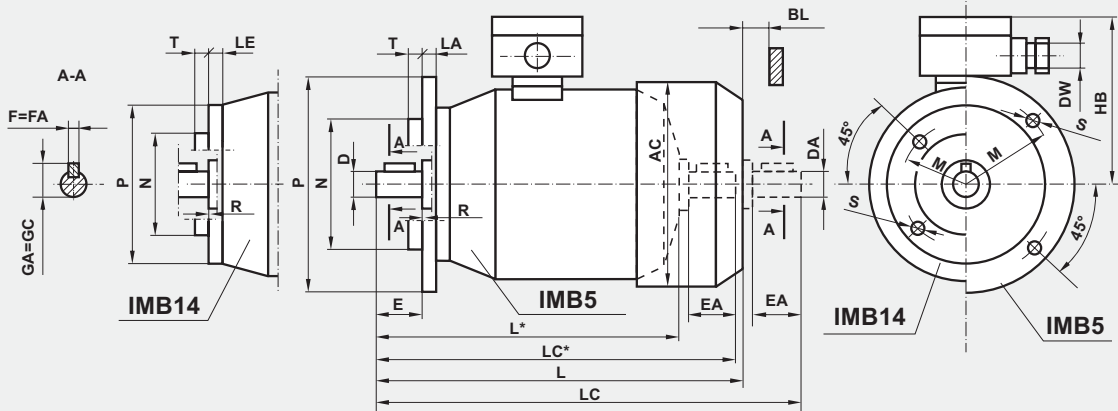

Forma wykonania IMB5

Type of construction IMB5

Typ	Wymiary (mm)											Dimensions (mm)										Łożyska Bearings
	Frame size	Kołnierz Flange	P	M	N	S	D=DA	E=EA	F=FA	GA=GC	LA	T	R	DW	AC	BL min	HB	L L*	LC LC*			
SKg 56-2A	B5	120	100	80j6	7	9j6	20	3h9	10,2	8	3	0	M20	117	11	98	188	213,5	6201 2Z			
SKg 56-4A																	149*	171*				
SKg 56-2B																	196	221,5				
SKg 56-4B																	157*	179*				
SKg 56-6B																	196	221,5				

Forma wykonania IMB14

Type of construction IMB14

Typ	Wymiary (mm)											Dimensions (mm)										Łożyska Bearings
	Frame size	Kołnierz Flange	P	M	N	S	D=DA	E=EA	F=FA	GA=GC	LE	T	R	DW	AC	BL min	HB	L L*	LC LC*			
SKg 56-2A1	B14/1	105	85	70j6	M6	9j6	20	3h9	10,2	15	2,5	0	M20	117	11	98	188	213,5	6201 2Z			
SKg 56-2A2	B14/2	80	65	50j6	M5					12,5							149*	171*				
SKg 56-4A1	B14/1	105	85	70j6	M6					15							-	171*				
SKg 56-4A2	B14/2	80	65	50j6	M5					12,5												
SKg 56-2B1	B14/1	105	85	70j6	M6					15							117	11		98	196	221,5
SKg 56-2B2	B14/2	80	65	50j6	M5					12,5												
SKg 56-4B1	B14/1	105	85	70j6	M6					15							-	179*				
SKg 56-4B2	B14/2	80	65	50j6	M5					12,5												
SKg 56-6B1	B14/1	105	85	70j6	M6					15							117	11		98	196	221,5
SKg 56-6B2	B14/2	80	65	50j6	M5					12,5												

Producent zastrzega sobie możliwość zmian danych zawartych w karcie katalogowej wynikających z ciągłego doskonalenia wyrobu.

As part of our development program, we reserve the right to alter or amend any of the specifications without giving prior notice.



BESEL S.A.

FABRYKA SILNIKÓW ELEKTRYCZNYCH

SILNIKI INDUKCYJNE TRÓJFAZOWE O WZNIOSIE OSI WAŁU 63

Charakterystyka silników katalogowych:

- silniki ogólnego przeznaczenia do pracy w warunkach klimatu umiarkowanego,
- praca ciągła S1,
- napięcia znamionowe 230V/400V (Δ/Y),
- częstotliwość zasilania 50 Hz,
- temperatura otoczenia od -15°C do +40°C,
- kolor malowania RAL 5010.

THREE-PHASE INDUCTION MOTORS FRAME SIZE 63

Description of the catalogue motors:

- general purpose motors; temperate climate,
- duty S1,
- rated voltage 230V/400V (Δ/Y),
- frequency 50 Hz,
- ambient temperature from -15°C to +40°C,
- standard paint colour RAL 5010.



stopień ochrony: IP54 (IP55; IP56; IP 65; IP 66)
klasa izolacji F (klasa H na życzenie)

degree of protection: IP54 (IP55; IP56; IP 65; IP 66)
insulation class F (class H on request)

Typ	Moc		Prędkość obrotowa [min ⁻¹]	Prąd [A] przy		Sprawność η [%]	Współ- czynnik mocy $\cos \varphi_N$	Moment znamio- nowy M _N [Nm]	Krotność prądu rozrucho- wego I _r /I _N	Krotność momentu rozrucho- wego M _r /M _N	$\frac{M_{max}}{M_N}$	Moment bezwładności J [kgm ²]	Masa [kg]
	[kW]	[KM]		230 V Δ	400 V Y								
Frame size	Rated output		Rated speed [min ⁻¹]	Rated current [A] at		Efficiency η [%]	Power factor $\cos \varphi_N$	Torque T _N [Nm]	Starting current/ rated current I _L /I _N	Starting torque/ rated torque T _L /T _N	$\frac{T_b}{T_N}$	Moment of inertia J [kgm ²]	Motor weight [kg]
	[kW]	[HP]		230 V Δ	400 V Y								

Silniki 2-biegunowe, 3000 min⁻¹; 50Hz

2-pole motors, 3000 min⁻¹; 50Hz

Sg 63-2A	0,18	0,25	2760	0,95	0,55	65	0,80	0,62	3,8	1,9	1,9	0,000175	3,6
Sg 63-2B	0,25	0,33	2760	1,10	0,65	68	0,83	0,87	4,0	2,0	2,0	0,000235	4,2

Silniki 4-biegunowe, 1500 min⁻¹; 50Hz

4-pole motors, 1500 min⁻¹; 50Hz

Sg 63-4A	0,12	0,17	1380	0,80	0,45	60	0,65	0,83	3,2	2,0	2,0	0,000240	3,6
Sg 63-4B	0,18	0,25	1380	1,10	0,65	64	0,63	1,25	3,2	2,0	2,0	0,000307	4,2

Silniki 6-biegunowe, 1000 min⁻¹; 50Hz

6-pole motors, 1000 min⁻¹; 50Hz

Sg 63-6A	0,09	0,12	820	0,80	0,45	40	0,75	1,05	1,9	1,15	1,3	0,000240	3,6
Sg 63-6B	0,12	0,17	880	0,85	0,60	53	0,70	1,30	2,6	1,10	1,6	0,000307	4,2

Silniki 8-biegunowe, 750 min⁻¹; 50Hz

8-pole motors, 750 min⁻¹; 50Hz

Sg 63-8A	0,04	0,06	670	0,60	0,35	35	0,60	0,57	1,7	1,6	1,7	0,000240	3,6
Sg 63-8B	0,06	0,08	670	0,80	0,45	38	0,60	0,86	1,7	1,6	1,7	0,000307	4,2

Silniki mogą być wykonane i certyfikowane na zgodność z wymogami normy UL 1004 lub CSA C22.2 No 100-04.

Silniki odpowiadają wymaganiom Polskiej Normy PN-EN 60034-1 oraz normom międzynarodowym IEC 60034-1.

Wszystkie silniki posiadają znak CE.

Motors may be certified for safety that they are manufactured according to the requirements of the UL 1004 or CSA C22.2 No 100-04.

Motors meet requirements of Polish Standard PN-EN 60034-1 and the international rules IEC 60034-1.

All motors are provided with CE mark.

Silniki na łapach
Forma wykonania
IMB3

Foot - mounted motors
Type of construction
IMB3

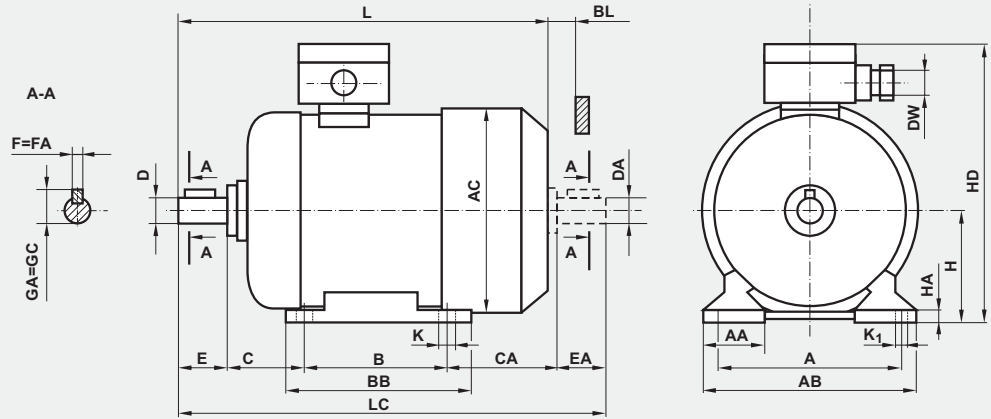

Forma wykonania IMB3

Type of construction IMB3

Typ	Wymiary (mm)																Dimensions (mm)				Łożyska Bearings	
	Frame size	A	B	C	CA	D=DA	E=EA	F=FA	GA=GC	H	K	K ₁	DW	AA	AB	AC	BB	BL _{min}	HA	HD		L
Sg 63-A	100	80	40	67	11j6	23	4h9	12,5	63,0,5	7	10	M20	36	124	126	106	11	8,5	165	201	233	6202 2Z
Sg 63-B				79																213	245	

Silniki kołnierzowe
Formy wykonania
IMB5, IMB14

Flange
- mounted motors
Types of construction
IMB5, IMB14

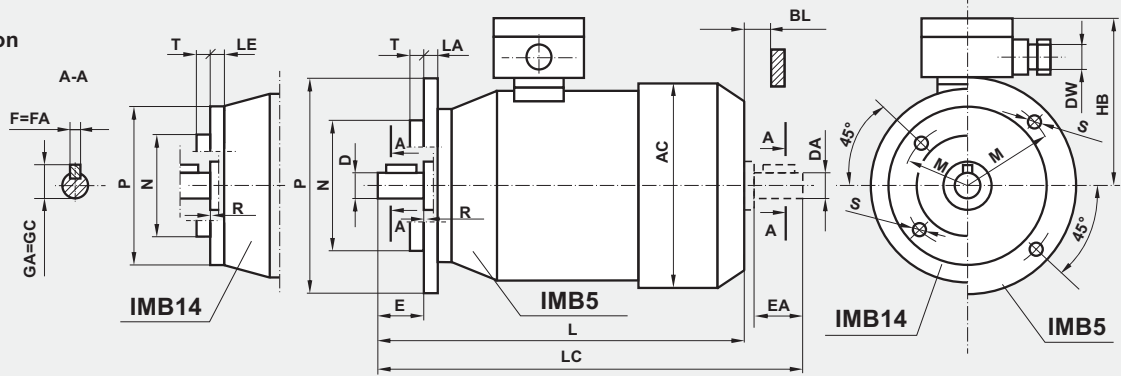

Forma wykonania IMB5

Type of construction IMB5

Typ	Wymiary (mm)										Dimensions (mm)						Łożyska Bearings		
	Frame size	Kołnierz Flange	P	M	N	S	D=DA	E=EA	F=FA	GA=GC	LA	T	R	DW	AC	BL _{min}		HB	L
SKg 63-A	B5	140	115	95j6	10	11j6	23	4h9	12,5	9	3	0	M20	126	11	102	201	233	6202 2Z
SKg 63-B																	213	245	

Forma wykonania IMB14

Type of construction IMB14

Typ	Wymiary (mm)										Dimensions (mm)						Łożyska Bearings		
	Frame size	Kołnierz Flange	P	M	N	S	D=DA	E=EA	F=FA	GA=GC	LE	T	R	DW	AC	BL _{min}		HB	L
SKg 63-A1	B14/1	120	100	80j6	M6	11j6	23	4h9	12,5	14	3	0	M20	126	11	102	201	233	6202 2Z
SKg 63-A2	B14/2	90	75	60j6	M5					9,5	2,5						213	245	
SKg 63-B1	B14/1	120	100	80j6	M6					14	3								
SKg 63-B2	B14/2	90	75	60j6	M5					9,5	2,5								

Producent zastrzega sobie możliwość zmian danych zawartych w karcie katalogowej wynikających z ciągłego doskonalenia wyrobu.

As part of our development program, we reserve the right to alter or amend any of the specifications without giving prior notice.



BESEL S.A.

FABRYKA SILNIKÓW ELEKTRYCZNYCH

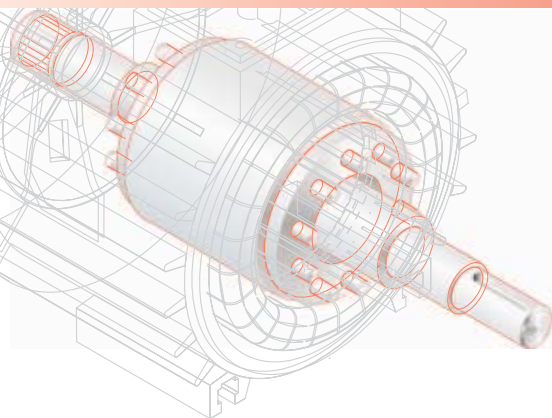

SILNIKI INDUKCYJNE TRÓJFAZOWE serii h O WZNIOSIE OSI WAŁU 71

Charakterystyka silników katalogowych:

- silniki ogólnego przeznaczenia do pracy w warunkach klimatu umiarkowanego,
- praca ciągła S1,
- napięcia znamionowe 230V/400V (Δ/Y),
- częstotliwość zasilania 50 Hz,
- temperatura otoczenia od -15°C do $+40^{\circ}\text{C}$,
- kolor malowania RAL 5010.



THREE-PHASE INDUCTION MOTORS series h FRAME SIZE 71

Description of the catalogue motors:

- general purpose motors; temperate climate,
- duty S1,
- rated voltage 230V/400V (Δ/Y),
- frequency 50 Hz,
- ambient temperature from -15°C to $+40^{\circ}\text{C}$,
- standard paint colour RAL 5010.

stopień ochrony: IP54 (IP55; IP56; IP 65; IP 66)
klasa izolacji F (klasa H na życzenie)

degree of protection: IP54 (IP55; IP56; IP 65; IP 66)
insulation class F (class H on request)

Typ	Moc		Prędkość obrotowa [min ⁻¹]	Prąd [A] przy		Sprawność η [%]	Współ- czynnik mocy $\cos \varphi_N$	Moment znamio- nowy M_N [Nm]	Krotność prądu rozruch- owego I_r/I_N	Krotność momentu rozruch- owego M_r/M_N	$\frac{M_{max}}{M_N}$	Moment bezwładności J [kgm ²]	Masa [kg]
	[kW]	[KM]		230 V Δ	400 V Y								
Frame size	Rated output		Rated speed [min ⁻¹]	Rated current [A] at		Efficiency η [%]	Power factor $\cos \varphi_N$	Torque T_N [Nm]	Starting current/ rated current I_L/I_N	Starting torque/ rated torque T_L/T_N	$\frac{T_b}{T_N}$	Moment of inertia J [kgm ²]	Motor weight [kg]
	[kW]	[HP]		230 V Δ	400 V Y								

Silniki 2-biegowe, 3000 min⁻¹; 50Hz

2-pole motors, 3000 min⁻¹; 50Hz

Sh 71-2A	0,37	0,50	2800	1,73	1,00	71	0,77	1,26	4,4	2,2	2,2	0,00039	5,0
Sh 71-2B	0,55	0,75	2790	2,35	1,35	75	0,82	1,88	4,0	2,0	2,1	0,00048	6,0

Silniki 4-biegowe, 1500 min⁻¹; 50Hz

4-pole motors, 1500 min⁻¹; 50Hz

Sh 71-4A	0,25	0,33	1380	1,50	0,85	66	0,64	1,73	3,0	2,0	2,0	0,00061	4,8
Sh 71-4B	0,37	0,50	1370	2,20	1,25	68	0,68	2,59	3,1	2,1	2,1	0,00077	5,9

Silniki 6-biegowe, 1000 min⁻¹; 50Hz

6-pole motors, 1000 min⁻¹; 50Hz

Sh 71-6A	0,18	0,25	890	1,30	0,75	57	0,68	1,91	2,6	1,9	1,9	0,000736	4,8
Sh 71-6B	0,25	0,33	860	1,75	1,00	55	0,79	2,78	2,0	1,6	1,6	0,000946	5,8

Silniki 8-biegowe, 750 min⁻¹; 50Hz

8-pole motors, 750 min⁻¹; 50Hz

Sh 71-8A	0,09	0,12	680	1,30	0,75	35	0,50	1,26	1,9	1,9	1,9	0,000736	4,9
Sh 71-8B	0,12	0,17	670	1,25	0,70	47	0,63	1,71	1,9	1,7	1,8	0,000946	5,8

Silniki mogą być wykonane i certyfikowane na zgodność z wymogami normy UL 1004 lub CSA C22.2 No 100-04.

Silniki odpowiadają wymaganiom Polskiej Normy PN-EN 60034-1 oraz normom międzynarodowym IEC 60034-1.

Wszystkie silniki posiadają znak CE.

Motors may be certified for safety that they are manufactured according to the requirements of the UL 1004 or CSA C22.2 No 100-04.

Motors meet requirements of Polish Standard PN-EN 60034-1 and the international rules IEC 60034-1.

All motors are provided with CE mark.

Silniki na łapach
Forma wykonania
IMB3

Foot - mounted motors
Type of construction
IMB3

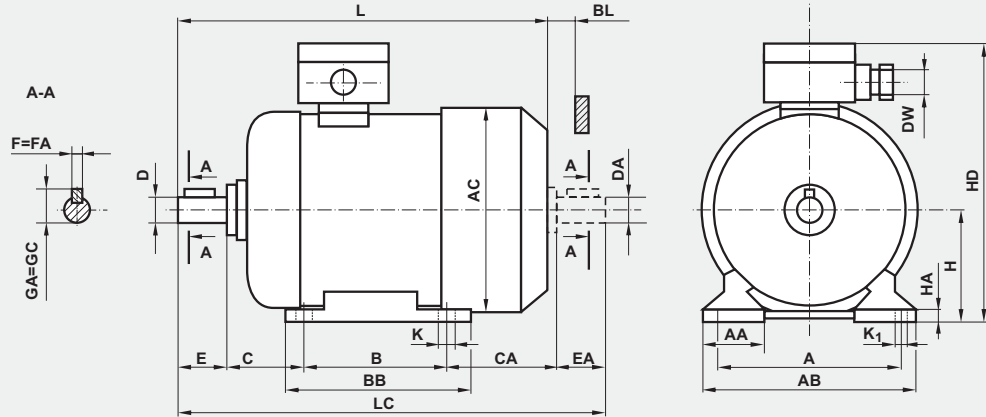

Forma wykonania IMB3

Type of construction IMB3

Typ Frame size	Wymiary (mm)																Dimensions (mm)				Łożyska Bearings	
	A	B	C	CA	D=DA	E=EA	F=FA	GA=GC	H	K	K ₁	DW	AA	AB	AC	BB	BL _{min}	HA	HD	L		LC
Sh 71-A	112	90	45	65	14j6	30	5h9	16	71 _{-0,5}	7	10	M20	45	142	141	116	12	8	182	223	261	6203 2Z
Sh 71-B				88																245	283	

Silniki kołnierkowe
Formy wykonania
IMB5, IMB14

Flange
- mounted motors
Types of construction
IMB5, IMB14

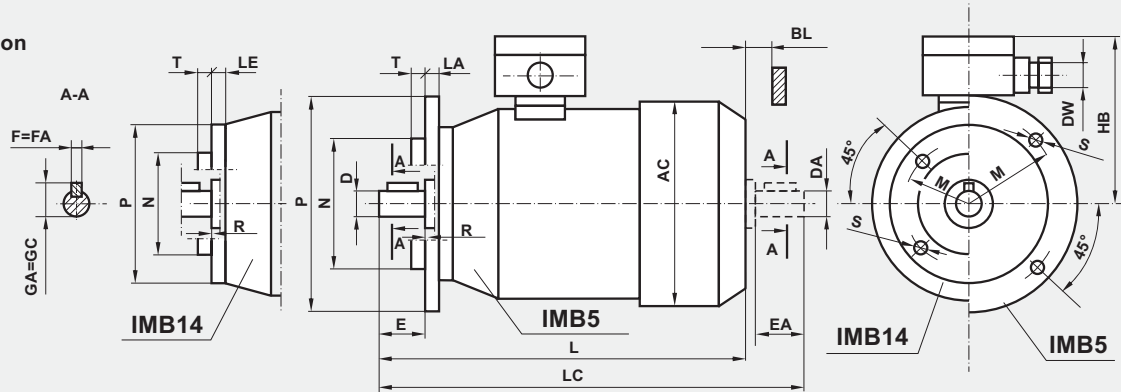

Forma wykonania IMB5

Type of construction IMB5

Typ Frame size	Wymiary (mm)										Dimensions (mm)								Łożyska Bearings
	Kołnierz Flange	P	M	N	S	D=DA	E=EA	F=FA	GA=GC	LA	T	R	DW	AC	BL _{min}	HB	L	LC	
SKh 71-A	B5	160	130	110j6	10	14j6	30	5h9	16	9	3,5	0	M20	141	12	111	223	261	6203 2Z
SKh 71-B																	245	283	

Forma wykonania IMB14

Type of construction IMB14

Typ Frame size	Wymiary (mm)										Dimensions (mm)								Łożyska Bearings
	Kołnierz Flange	P	M	N	S	D=DA	E=EA	F=FA	GA=GC	LE	T	R	DW	AC	BL _{min}	HB	L	LC	
SKh 71-A1	B14/1	140	115	95j6	M8	14j6	30	5h9	16	14	3	0	M20	141	12	111	223	261	6203 2Z
SKh 71-A2	B14/2	105	85	70j6	M6					12	2,5								
SKh 71-B1	B14/1	140	115	95j6	M8					14	3								
SKh 71-B2	B14/2	105	85	70j6	M6					12	2,5								

Producent zastrzega sobie możliwość zmian danych zawartych w karcie katalogowej wynikających z ciągłego doskonalenia wyrobu.

As part of our development program, we reserve the right to alter or amend any of the specifications without giving prior notice.



BESEL S.A.

FABRYKA SILNIKÓW ELEKTRYCZNYCH

SILNIKI INDUKCYJNE TRÓJFAZOWE serii h O WZNIOSIE OSI WAŁU 80

Charakterystyka silników katalogowych:

- silniki ogólnego przeznaczenia do pracy w warunkach klimatu umiarkowanego,
- praca ciągła S1,
- napięcia znamionowe 230V/400V (Δ/Y),
- częstotliwość zasilania 50 Hz,
- temperatura otoczenia od -15°C do $+40^{\circ}\text{C}$,
- kolor malowania RAL 5010.

THREE-PHASE INDUCTION MOTORS series h FRAME SIZE 80

Description of the catalogue motors:

- general purpose motors; temperate climate,
- duty S1,
- rated voltage 230V/400V (Δ/Y),
- frequency 50 Hz,
- ambient temperature from -15°C to $+40^{\circ}\text{C}$,
- standard paint colour RAL 5010.

stopień ochrony: IP54 (IP55; IP56; IP 65; IP 66)
klasa izolacji F (klasa H na życzenie)

degree of protection: IP54 (IP55; IP56; IP 65; IP 66)
insulation class F (class H on request)

Typ	Moc		Prędkość obrotowa [min ⁻¹]	Prąd [A] przy		Sprawność η [%]	Współ- czynnik mocy $\cos \varphi_N$	Moment znamio- nowy M _N [Nm]	Krotność prądu rozrucho- wego I _L /I _N	Krotność momentu rozrucho- wego M _r /M _N	$\frac{M_{max}}{M_N}$	Moment bezwładności J [kgm ²]	Masa [kg]
	[kW]	[KM]		230 V Δ	400 V Y								
Frame size	Rated output		Rated speed [min ⁻¹]	Rated current [A] at		Efficiency η [%]	Power factor $\cos \varphi_N$	Torque T _N [Nm]	Starting current/ rated current I _L /I _N	Starting torque/ rated torque T _L /T _N	$\frac{T_b}{T_N}$	Moment of inertia J [kgm ²]	Motor weight [kg]
	[kW]	[HP]		230 V Δ	400 V Y								

Silniki 2-biegunowe, 3000 min⁻¹; 50Hz

2-pole motors, 3000 min⁻¹; 50Hz

Sh 80-2A	0,75	1,00	2800	3,30	1,90	74	0,80	2,56	4,5	2,7	2,6	0,000829	7,8
Sh 80-2B	1,10	1,50	2780	4,30	2,50	77	0,84	3,78	5,1	2,6	2,6	0,001005	9,1

Silniki 4-biegunowe, 1500 min⁻¹; 50Hz

4-pole motors, 1500 min⁻¹; 50Hz

Sh 80-4A	0,55	0,75	1400	2,70	1,60	72	0,71	3,75	3,6	2,0	2,1	0,001578	7,5
Sh 80-4B	0,75	1,00	1390	3,50	2,00	75	0,73	5,15	4,0	2,1	2,1	0,001874	8,8

Silniki 6-biegunowe, 1000 min⁻¹; 50Hz

6-pole motors, 1000 min⁻¹; 50Hz

Sh 80-6A	0,37	0,50	910	2,40	1,40	64	0,65	3,88	3,0	2,0	2,1	0,001693	7,4
Sh 80-6B	0,55	0,75	900	3,10	1,80	67	0,70	5,84	2,7	1,9	2,0	0,002070	8,6

Silniki 8-biegunowe, 750 min⁻¹; 50Hz

8-pole motors, 750 min⁻¹; 50Hz

Sh 80-8A	0,18	0,25	680	1,55	0,90	53	0,57	2,53	2,3	1,8	2,0	0,001693	7,5
Sh 80-8B	0,25	0,33	680	2,10	1,20	57	0,60	3,51	2,5	1,7	1,7	0,002070	8,9

Silniki mogą być wykonane i certyfikowane na zgodność z wymogami normy UL 1004 lub CSA C22.2 No 100-04.

Silniki odpowiadają wymaganiom Polskiej Normy PN-EN 60034-1 oraz normom międzynarodowym IEC 60034-1.

Wszystkie silniki posiadają znak CE.

Motors may be certified for safety that they are manufactured according to the requirements of the UL 1004 or CSA C22.2 No 100-04.

Motors meet requirements of Polish Standard PN-EN 60034-1 and the international rules IEC 60034-1.

All motors are provided with CE mark.

Silniki na łapach
Forma wykonania
IMB3

Foot - mounted motors
Type of construction
IMB3

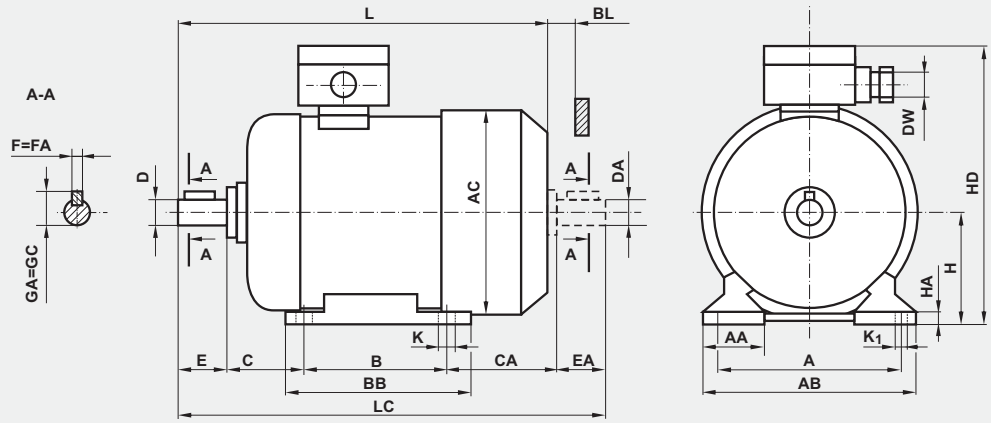

Forma wykonania IMB3

Type of construction IMB3

Typ Frame size	Wymiary (mm)																Dimensions (mm)				Łożyska Bearings	
	A	B	C	CA	D=DA	E=EA	F=FA	GA=GC	H	K	K ₁	DW	AA	AB	AC	BB	BL _{min}	HA	HD	L		LC
Sh 80-A	125	100	50	87	19j6	40	6h9	21,5	80 _{-0,5}	10	13	M20	55	160	157	130	15	9	200	266	317	6204 2Z
Sh 80-B				99															278	329		

Silniki kołnierowe
Formy wykonania
IMB5, IMB14

Flange
- mounted motors
Types of construction
IMB5, IMB14

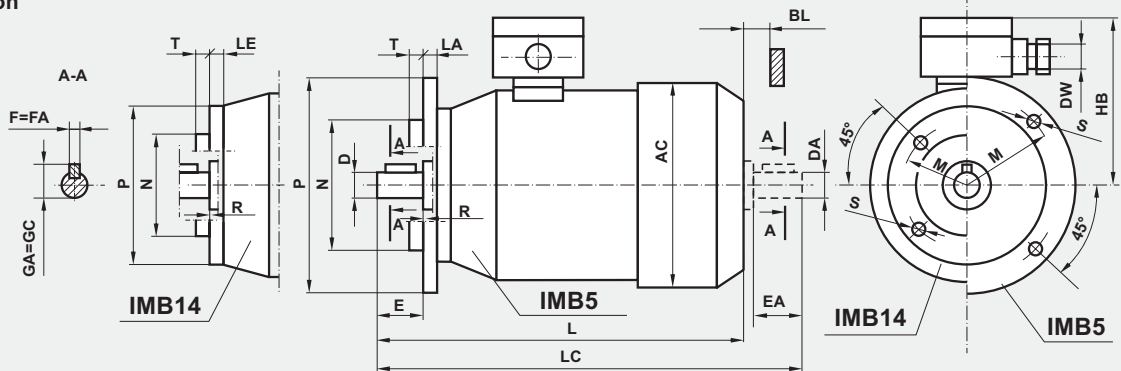

Forma wykonania IMB5

Type of construction IMB5

Typ Frame size	Wymiary (mm)											Dimensions (mm)							Łożyska Bearings
	Kołnier Flange	P	M	N	S	D=DA	E=EA	F=FA	GA=GC	LA	T	R	DW	AC	BL _{min}	HB	L	LC	
SKh 80-A	B5	200	165	130j6	12	19j6	40	6h9	21,5	10	3,5	0	M20	157	15	120	266	317	6204 2Z
SKh 80-B		278	329																

Forma wykonania IMB14

Type of construction IMB14

Typ Frame size	Wymiary (mm)											Dimensions (mm)							Łożyska Bearings
	Kołnier Flange	P	M	N	S	D=DA	E=EA	F=FA	GA=GC	LE	T	R	DW	AC	BL _{min}	HB	L	LC	
SKh 80-A1	B14/1	160	130	110j6	M8	19j6	40	6h9	21,5	14	3,5	0	M20	157	15	120	266	317	6204 2Z
SKh 80-A2	B14/2	120	100	80j6	M6					12	3						278	329	
SKh 80-B1	B14/1	160	130	110j6	M8					14	3,5								
SKh 80-B2	B14/2	120	100	80j6	M6					12	3								

Producent zastrzega sobie możliwość zmian danych zawartych w karcie katalogowej wynikających z ciągłego doskonalenia wyrobu.

As part of our development program, we reserve the right to alter or amend any of the specifications without giving prior notice.



BESEL S.A.

FABRYKA SILNIKÓW ELEKTRYCZNYCH

SILNIKI INDUKCYJNE TRÓJFAZOWE serii h O WZNIOSIE OSI WAŁU 90

Charakterystyka silników katalogowych:

- silniki ogólnego przeznaczenia do pracy w warunkach klimatu umiarkowanego,
- praca ciągła S1,
- napięcia znamionowe 230V/400V (Δ/Y),
- częstotliwość zasilania 50 Hz,
- temperatura otoczenia od -15°C do $+40^{\circ}\text{C}$,
- kolor malowania RAL 5010.

THREE-PHASE INDUCTION MOTORS series h FRAME SIZE 90

Description of the catalogue motors:

- general purpose motors; temperate climate,
- duty S1,
- rated voltage 230V/400V (Δ/Y),
- frequency 50 Hz,
- ambient temperature from -15°C to $+40^{\circ}\text{C}$,
- standard paint colour RAL 5010.

stopień ochrony: IP54 (IP55; IP56; IP 65; IP 66)
klasa izolacji F (klasa H na życzenie)

degree of protection: IP54 (IP55; IP56; IP 65; IP 66)
insulation class F (class H on request)

Typ	Moc		Prędkość obrotowa [min ⁻¹]	Prąd [A] przy		Sprawność η [%]	Współ- czynnik mocy $\cos \varphi_N$	Moment znamio- nowy M _N [Nm]	Krotność prądu rozrucho- wego I _r /I _N	Krotność momentu rozrucho- wego M _r /M _N	$\frac{M_{max}}{M_N}$	Moment bezwładności J [kgm ²]	Masa [kg]
	[kW]	[KM]		230 V Δ	400 V Y								
Frame size	Rated output		Rated speed [min ⁻¹]	Rated current [A] at		Efficiency η [%]	Power factor $\cos \varphi_N$	Torque T _N [Nm]	Starting current/ rated current I _L /I _N	Starting torque/ rated torque T _L /T _N	$\frac{T_b}{T_N}$	Moment of inertia J [kgm ²]	Motor weight [kg]
	[kW]	[HP]		230 V Δ	400 V Y								

Silniki 2-biegunowe, 3000 min⁻¹; 50Hz

2-pole motors, 3000 min⁻¹; 50Hz

Sh 90-2S	1,50	2,00	2800	5,90	3,40	79	0,84	5,12	5,0	3,0	2,8	0,0012	11,6
Sh 90-2L	2,20	3,00	2820	9,00	5,20	81	0,75	7,45	5,3	3,2	3,0	0,0016	13,2

Silniki 4-biegunowe, 1500 min⁻¹; 50Hz

4-pole motors, 1500 min⁻¹; 50Hz

Sh 90-4S	1,10	1,50	1380	5,00	2,90	76	0,76	7,61	4,0	1,7	2,0	0,0024	11,0
Sh 90-4L	1,50	2,00	1380	7,45	4,30	78	0,72	10,38	3,8	2,4	2,2	0,0032	12,5

Silniki 6-biegunowe, 1000 min⁻¹; 50Hz

6-pole motors, 1000 min⁻¹; 50Hz

Sh 90-6S	0,75	1,00	900	4,00	2,30	72	0,72	8,00	3,4	2,1	2,0	0,0024	10,8
Sh 90-6L	1,10	1,50	900	5,50	3,20	74	0,68	12,40	2,0	1,6	1,5	0,0032	12,5

Silniki 8-biegunowe, 750 min⁻¹; 50Hz

8-pole motors, 750 min⁻¹; 50Hz

Sh 90-8S	0,37	0,50	680	2,95	1,70	58	0,60	5,20	2,5	2,0	2,0	0,0024	11,0
Sh 90-8L	0,55	0,75	690	4,20	2,40	59	0,60	7,60	2,5	2,1	2,2	0,0032	12,7

Silniki mogą być wykonane i certyfikowane na zgodność z wymogami normy UL 1004 lub CSA C22.2 No 100-04.

Motors may be certified for safety that they are manufactured according to the requirements of the UL 1004 or CSA C22.2 No 100-04.

Silniki odpowiadają wymaganiom Polskiej Normy PN-EN 60034-1 oraz normom międzynarodowym IEC 60034-1.

Motors meet requirements of Polish Standard PN-EN 60034-1 and the international rules IEC 60034-1.

Wszystkie silniki posiadają znak CE.

All motors are provided with CE mark.

Silniki na łapach
Forma wykonania
IMB3

Foot - mounted motors
Type of construction
IMB3

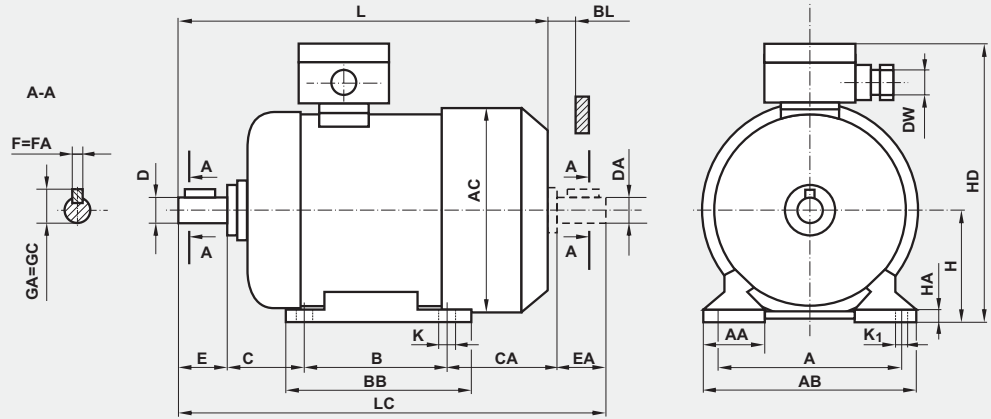

Forma wykonania IMB3

Type of construction IMB3

Typ Frame size	Wymiary (mm)																Dimensions (mm)				Łożyska Bearings		
	A	B	C	CA	D=DA	E=EA	F=FA	GA=GC	H	K	K ₁	DW	AA	AB	AC	BB	BL _{min}	HA	HD	L	LC	P	N
	Sh 90-S	140	100	56	114	24j6	50	8h9	27	90 _{-0,5}	10	13	M20	60	170	157	153	15	12	208	316		
Sh 90-L		125		107																328	388		

Silniki kołnierkowe
Formy wykonania
IMB5, IMB14

Flange - mounted motors
Types of construction
IMB5, IMB14

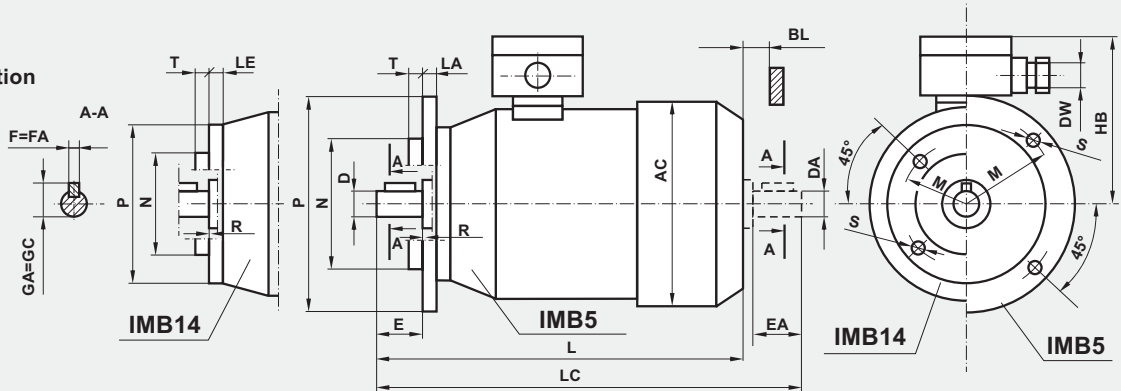

Forma wykonania IMB5

Type of construction IMB5

Typ Frame size	Wymiary (mm)										Dimensions (mm)							Łożyska Bearings			
	Kołnierz Flange		P	M	N	S	D=DA	E=EA	F=FA	GA=GC	LA	T	R	DW	AC	BL _{min}	HB	L	LC	P	N
	SKh 90-S	B5	200	165	130j6	12	24j6	50	8h9	27	10	3,5	0	M20	157	15	118	316	376		
SKh 90-L	328																	388			

Forma wykonania IMB14

Type of construction IMB14

Typ Frame size	Wymiary (mm)										Dimensions (mm)							Łożyska Bearings			
	Kołnierz Flange		P	M	N	S	D=DA	E=EA	F=FA	GA=GC	LE	T	R	DW	AC	BL _{min}	HB	L	LC	P	N
	SKh 90-S1	B14/1	160	130	110j6	M8	24j6	50	8h9	27	10	3,5	0	M20	157	15	118	316	376		
SKh 90-S2	10										3										
SKh 90-L1	10										3,5										
SKh 90-L2	10										3										

Producent zastrzega sobie możliwość zmian danych zawartych w karcie katalogowej wynikających z ciągłego doskonalenia wyrobu.

As part of our development program, we reserve the right to alter or amend any of the specifications without giving prior notice.