

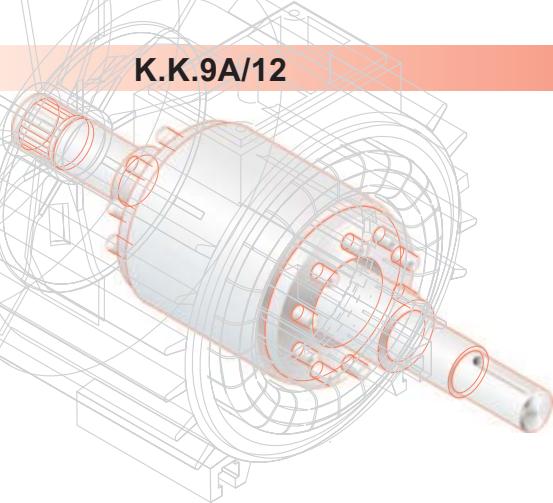

BESEL S.A.

FABRYKA SILNIKÓW ELEKTRYCZNYCH



SILNIKI INDUKCYJNE TRÓJFAZOWE O WZNIOSIE OSI WAŁU 56 serii h

Charakterystyka silników katalogowych:

- silniki ogólnego przeznaczenia do pracy w warunkach klimatu umiarkowanego,
- praca ciągła S1,
- napięcia znamionowe 230V/400V (Δ/Y),
- częstotliwość zasilania 50 Hz,
- temperatura otoczenia od -15°C do $+40^{\circ}\text{C}$,
- kolor malowania RAL 5010.



THREE-PHASE INDUCTION MOTORS FRAME SIZE 56 series h

Description of the catalogue motors:

- general purpose motors; temperate climate,
- duty S1,
- rated voltage 230V/400V (Δ/Y),
- frequency 50 Hz,
- ambient temperature from -15°C to $+40^{\circ}\text{C}$,
- standard paint colour RAL 5010.

stopień ochrony: IP54 (IP55; IP56; IP 65; IP 66)
klasa izolacji F (klasa H na życzenie)

degree of protection: IP54 (IP55; IP56; IP 65; IP 66)
insulation class F (class H on request)

Typ	Moc		Prędkość obrotowa [min ⁻¹]	Prąd [A] przy		Sprawność η [%]	Współczynnik mocy $\cos \varphi_N$	Moment znamionowy M_N [Nm]	Krotność prądu rozruchowego I_r/I_N	Krotność momentu rozruchowego M_r/M_N	$\frac{M_{max}}{M_N}$	Moment bezwładności J [kgm ²]	Masa [kg]
	[kW]	[KM]		230 V Δ	400 V Y								
Frame size	Rated output		Rated speed [min ⁻¹]	Rated current [A] at		Efficiency η [%]	Power factor $\cos \varphi_N$	Torque T_N [Nm]	Starting current/ rated current I_L/I_N	Starting torque/ rated torque T_L/T_N	$\frac{T_b}{T_N}$	Moment of inertia J [kgm ²]	Motor weight [kg]
	[kW]	[HP]		230 V Δ	400 V Y								

Silniki 2-biegowe, 3000 min⁻¹; 50Hz

2-pole motors, 3000 min⁻¹; 50Hz

Sh 56-2A	0,09	0,12	2820	0,60	0,35	62,0	0,63	0,30	3,4	2,5	2,7	0,000076	2,9
Sh 56-2B	0,12	0,17	2800	0,70	0,40	65,0	0,73	0,41	3,0	2,0	2,0	0,000095	3,2
Sh 56x-2C	0,18	0,25	2840	1,20	0,70	66,0	0,60	0,60	3,6	2,9	2,7	0,000100	3,5

Silniki 4-biegowe, 1500 min⁻¹; 50Hz

4-pole motors, 1500 min⁻¹; 50Hz

Sh 56-4A	0,06	0,08	1400	0,45	0,25	55,0	0,63	0,41	2,8	2,0	2,3	0,000145	2,6
Sh 56-4B	0,09	0,12	1400	0,70	0,40	58,0	0,60	0,61	2,6	2,1	2,3	0,000186	2,8
Sh 56x-4C	0,12	0,17	1400	1,20	0,70	52,0	0,55	0,82	2,2	2,2	2,4	0,000300	3,3

Silniki 6-biegowe, 1000 min⁻¹; 50Hz

6-pole motors, 1000 min⁻¹; 50Hz

Sh 56-6B	0,06	0,08	900	0,65	0,40	40	0,63	0,64	1,8	1,3	1,5	0,000186	2,8
----------	------	------	-----	------	------	----	------	------	-----	-----	-----	----------	-----

Silniki mogą być wykonane i certyfikowane na zgodność z wymogami normy UL 1004 lub CSA C22.2 No 100-04.

Silniki odpowiadają wymaganiom Polskiej Normy PN-EN 60034-1 oraz normom międzynarodowym IEC 60034-1.

Wszystkie silniki posiadają znak CE.

Motors may be certified for safety that they are manufactured according to the requirements of the UL 1004 or CSA C22.2 No 100-04.

Motors meet requirements of Polish Standard PN-EN 60034-1 and the international rules IEC 60034-1.

All motors are provided with CE mark.

Silniki na łapach
Forma wykonania
IMB3

Foot - mounted motors
Type of construction
IMB3

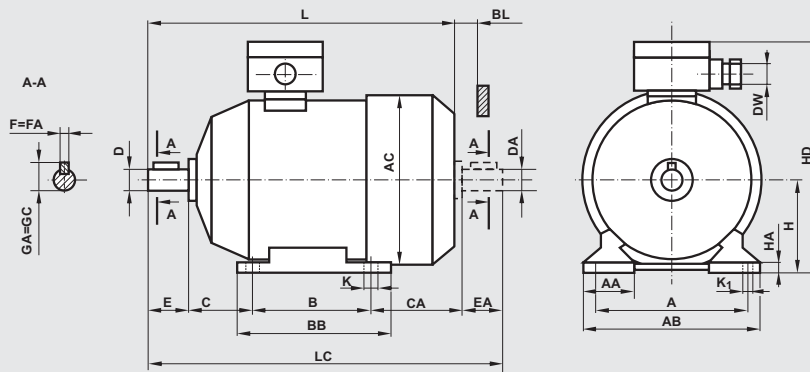

Forma wykonania IMB3

Type of construction IMB3

Typ	Wymiary (mm)																Dimensions (mm)					Łożyska Bearings			
	Frame size		A	B	C	CA	D=DA	E=EA	F=FA	GA=GC	H	K	K ₁	DW	AA	AB	AC	BB	BL _{min}	HA	HD		L	LC	
Sh 56-2A	90	71	36	66,5	9j6	20	3h9	10,2	56-0,5	5,8	8	M20	30	110	117	92	11	7	154	193	216,5	208,5	208,5	6201 2Z	
Sh 56-4A																									
Sh 56-2B																									
Sh 56-4B				74,5																					
Sh 56-6B																									
Sh 56x-2C				82,5																					
Sh 56x-4C																									

Silniki kołnierzowe
Formy wykonania
IMB5, IMB14

Flange - mounted motors
Types of construction
IMB5, IMB14

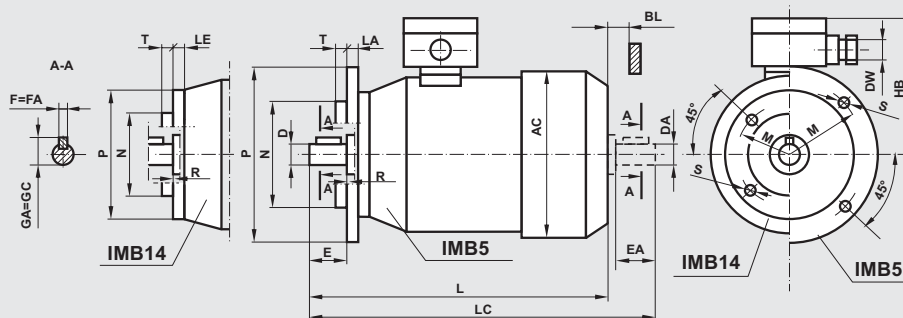

Forma wykonania IMB5

Type of construction IMB5

Typ	Wymiary (mm)										Dimensions (mm)							Łożyska Bearings				
	Frame size		Kołnierz Flange		P	M	N	S	D=DA	E=EA	F=FA	GA=GC	LA	T	R	DW	AC		BL _{min}	HB	L	LC
SKh 56-2A	B5	120	100	80j6	7	9j6	20	3h9	10,2	8	3	0	M20	117	11	98	193	216,5	183	208,5	208,5	6201 2Z
SKh 56-4A																						
SKh 56-2B																						
SKh 56-4B																						
SKh 56-6B																						
SKh 56x-2C																						
SKh 56x-4C																						

Forma wykonania IMB14

Type of construction IMB14

Typ	Wymiary (mm)										Dimensions (mm)							Łożyska Bearings				
	Frame size		Kołnierz Flange		P	M	N	S	D=DA	E=EA	F=FA	GA=GC	LE	T	R	DW	AC		BL _{min}	HB	L	LC
SKh 56-2A1	9j6	20	3h9	10,2	2,5	0	M20	117	11	98	193	216,5	183	208,5	208,5	6201 2Z						
SKh 56-2A2																	B14/1	105	85	70j6	M6	15
SKh 56-4A1																	B14/2	80	65	50j6	M5	12,5
SKh 56-4A2																	B14/1	105	85	70j6	M6	15
SKh 56-4A2																	B14/2	80	65	50j6	M5	12,5
SKh 56-2B1																	B14/1	105	85	70j6	M6	15
SKh 56-2B2																	B14/2	80	65	50j6	M5	12,5
SKh 56-4B1																	B14/1	105	85	70j6	M6	15
SKh 56-4B2																	B14/2	80	65	50j6	M5	12,5
SKh 56-6B1																	B14/1	105	85	70j6	M6	15
SKh 56-6B2																	B14/2	80	65	50j6	M5	12,5
SKh 56x-2C1																	B14/1	105	85	70j6	M6	15
SKh 56x-2C2																	B14/2	80	65	50j6	M5	12,5
SKh 56x-4C1																	B14/1	105	85	70j6	M6	15
SKh 56x-4C2																	B14/2	80	65	50j6	M5	12,5

Producent zastrzega sobie możliwość zmian danych zawartych w karcie katalogowej wynikających z ciągłego doskonalenia wyrobu.

As part of our development program, we reserve the right to alter or amend any of the specifications without giving prior notice.



BESEL S.A.

FABRYKA SILNIKÓW ELEKTRYCZNYCH

SILNIKI INDUKCYJNE TRÓJFAZOWE O WZNIOSIE OSI WAŁU 63 serii h

Charakterystyka silników katalogowych:

- silniki ogólnego przeznaczenia do pracy w warunkach klimatu umiarkowanego,
- praca ciągła S1,
- napięcia znamionowe 230V/400V (Δ/Y),
- częstotliwość zasilania 50 Hz,
- temperatura otoczenia od -15°C do $+40^{\circ}\text{C}$,
- kolor malowania RAL 5010.

THREE-PHASE INDUCTION MOTORS FRAME SIZE 63 series h

Description of the catalogue motors:

- general purpose motors; temperate climate,
- duty S1,
- rated voltage 230V/400V (Δ/Y),
- frequency 50 Hz,
- ambient temperature from -15°C to $+40^{\circ}\text{C}$,
- standard paint colour RAL 5010.



stopień ochrony: IP54 (IP55; IP56; IP 65; IP 66)
klasa izolacji F (klasa H na życzenie)

degree of protection: IP54 (IP55; IP56; IP 65; IP 66)
insulation class F (class H on request)

Typ	Moc		Prędkość obrotowa [min ⁻¹]	Prąd [A] przy		Sprawność η [%]	Współczynnik mocy $\cos \varphi_N$	Moment znamionowy M_N [Nm]	Krotność prądu rozruchowego I_r/I_N	Krotność momentu rozruchowego M_r/M_N	$\frac{M_{max}}{M_N}$	Moment bezwładności J [kgm ²]	Masa [kg]
	[kW]	[KM]		230 V Δ	400 V Y								
Frame size	Rated output		Rated speed [min ⁻¹]	Rated current [A] at		Efficiency η [%]	Power factor $\cos \varphi_N$	Torque T_N [Nm]	Starting current/ rated current I_L/I_N	Starting torque/ rated torque T_L/T_N	$\frac{T_b}{T_N}$	Moment of inertia J [kgm ²]	Motor weight [kg]
	[kW]	[HP]		230 V Δ	400 V Y								

Silniki 2-biegunowe, 3000 min⁻¹; 50Hz

2-pole motors, 3000 min⁻¹; 50Hz

Sh 63-2A	0,18	0,25	2760	0,85	0,50	65,0	0,80	0,62	3,4	2,1	2,1	0,000175	3,5
Sh 63-2B	0,25	0,33	2780	1,10	0,65	72,0	0,80	0,86	3,3	2,4	2,5	0,000235	4,1
Sh 63x-2C	0,37	0,50	2820	1,75	1,00	75,0	0,72	1,25	4,7	3,3	3,2	0,000310	5,0

Silniki 4-biegunowe, 1500 min⁻¹; 50Hz

4-pole motors, 1500 min⁻¹; 50Hz

Sh 63-4A	0,12	0,17	1380	0,80	0,45	60,0	0,65	0,83	2,6	1,9	2,0	0,000240	3,5
Sh 63-4B	0,18	0,25	1380	1,10	0,65	65,0	0,65	1,25	2,6	2,0	2,0	0,000307	4,1
Sh 63x-4C	0,25	0,33	1380	1,75	1,00	68,0	0,58	1,73	3,0	2,8	2,7	0,000380	5,0

Silniki 6-biegunowe, 1000 min⁻¹; 50Hz

6-pole motors, 1000 min⁻¹; 50Hz

Sh 63-6A	0,09	0,12	820	0,80	0,45	40	0,75	1,05	1,9	1,15	1,3	0,000240	3,5
Sh 63-6B	0,12	0,17	870	1,10	0,65	50	0,65	1,30	1,8	1,3	1,1	0,000307	4,1
Sh 63x-6C	0,15	0,20	870	1,90	1,10	42	0,55	1,65	1,8	2,0	1,9	0,000422	4,8

Silniki 8-biegunowe, 750 min⁻¹; 50Hz

8-pole motors, 750 min⁻¹; 50Hz

Sh 63-8A	0,04	0,06	670	0,60	0,35	35	0,60	0,57	1,7	1,6	1,7	0,000240	3,5
Sh 63-8B	0,06	0,08	660	0,85	0,50	35	0,63	0,87	1,5	1,4	1,6	0,000307	4,1
Sh 63x-8C	0,075	0,11	650	1,35	0,78	30	0,50	1,10	1,5	1,6	1,6	0,000422	5,0

Silniki mogą być wykonane i certyfikowane na zgodność z wymogami normy UL 1004 lub CSA C22.2 No 100-04.

Silniki odpowiadają wymaganiom Polskiej Normy PN-EN 60034-1 oraz normom międzynarodowym IEC 60034-1.

Wszystkie silniki posiadają znak CE.

Motors may be certified for safety that they are manufactured according to the requirements of the UL 1004 or CSA C22.2 No 100-04.

Motors meet requirements of Polish Standard PN-EN 60034-1 and the international rules IEC 60034-1.

All motors are provided with CE mark.

Silniki na łapach
Forma wykonania
IMB3

Foot - mounted motors
Type of construction
IMB3

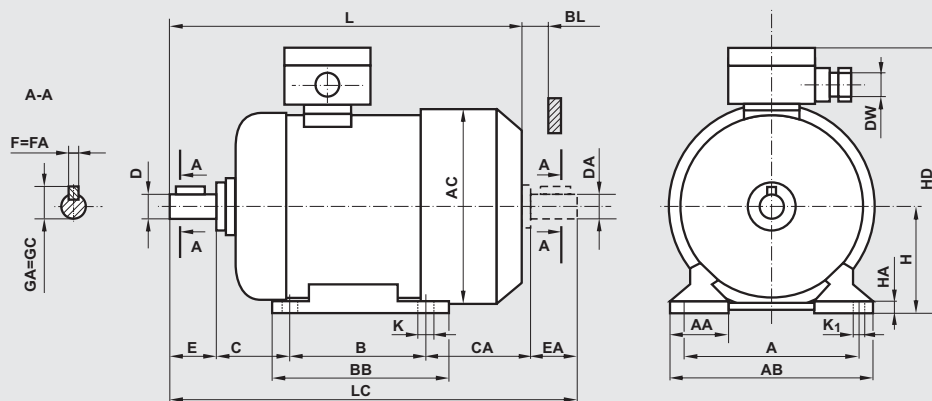

Forma wykonania IMB3

Type of construction IMB3

Typ Frame size	Wymiary (mm)																Dimensions (mm)				Łożyska Bearings	
	A	B	C	CA	D=DA	E=EA	F=FA	GA=GC	H	K	K ₁	DW	AA	AB	AC	BB	BL min	HA	HD	L		LC
Sh 63-A	100	80	40	67	11j6	23	4h9	12,5	63-0,5	7	10	M20	36	124	126	106	11	8,5	165	200	232	6202 2Z
Sh 63-B				79																210	242	
Sh 63x-C				94																225	257	

Silniki kołnierzone
Formy wykonania
IMB5, IMB14

Flange - mounted motors
Types of construction
IMB5, IMB14

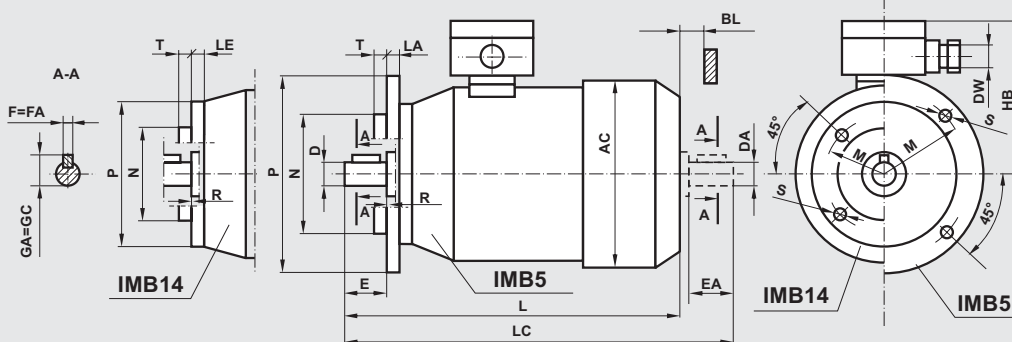

Forma wykonania IMB5

Type of construction IMB5

Typ Frame size	Wymiary (mm)											Dimensions (mm)						Łożyska Bearings	
	Kołnierz Flange	P	M	N	S	D=DA	E=EA	F=FA	GA=GC	LA	T	R	DW	AC	BL min	HB	L		LC
SKh 63-A	B5	140	115	95j6	10	11j6	23	4h9	12,5	9	3	0	M20	126	11	102	200	232	6202 2Z
SKh 63-B																	210	242	
SKh 63x-C																	225	257	

Forma wykonania IMB14

Type of construction IMB14

Typ Frame size	Wymiary (mm)											Dimensions (mm)						Łożyska Bearings	
	Kołnierz Flange	P	M	N	S	D=DA	E=EA	F=FA	GA=GC	LE	T	R	DW	AC	BL min	HB	L		LC
SKh 63-A1	B14/1	120	100	80j6	M6	11j6	23	4h9	12,5	14	3	0	M20	126	11	102	200	232	6202 2Z
SKh 63-A2	B14/2	90	75	60j6	M5					9,5	2,5								
SKh 63-B1	B14/1	120	100	80j6	M6					14	3								
SKh 63-B2	B14/2	90	75	60j6	M5					9,5	2,5								
SKh 63x-C1	B14/1	120	100	80j6	M6					14	3								
SKh 63x-C2	B14/2	90	75	60j6	M5					9,5	2,5								



BESEL S.A.

FABRYKA SILNIKÓW ELEKTRYCZNYCH

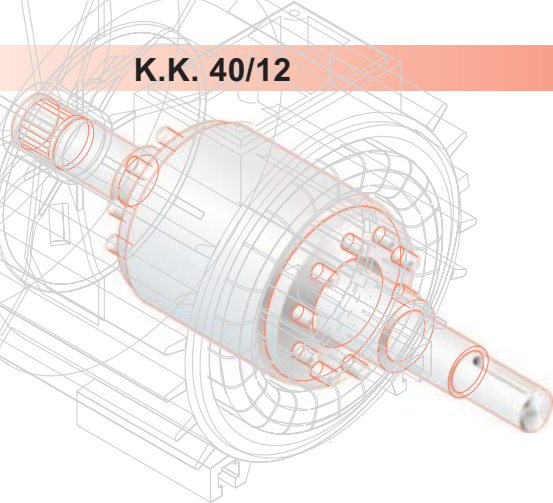

SILNIKI INDUKCYJNE TRÓJFAZOWE serii h O WZNIOSIE OSI WAŁU 71

Charakterystyka silników katalogowych:

- silniki ogólnego przeznaczenia do pracy w warunkach klimatu umiarkowanego,
- praca ciągła S1,
- napięcia znamionowe 230V/400V (Δ/Y),
- częstotliwość zasilania 50 Hz,
- temperatura otoczenia od -15°C do $+40^{\circ}\text{C}$,
- kolor malowania RAL 5010.

THREE-PHASE INDUCTION MOTORS series h FRAME SIZE 71

Description of the catalogue motors:

- general purpose motors; temperate climate,
- duty S1,
- rated voltage 230V/400V (Δ/Y),
- frequency 50 Hz,
- ambient temperature from -15°C to $+40^{\circ}\text{C}$,
- standard paint colour RAL 5010.

stopień ochrony: IP54 (IP55; IP56; IP 65; IP 66)
klasa izolacji F (klasa H na życzenie)

degree of protection: IP54 (IP55; IP56; IP 65; IP 66)
insulation class F (class H on request)

Typ	Moc		Prędkość obrotowa [min ⁻¹]	Prąd [A] przy		Sprawność η [%]	Współ- czynnik mocy $\cos \varphi_N$	Moment znamio- nowy M _N [Nm]	Krotność prądu rozrucho- wego I _r /I _N	Krotność momentu rozrucho- wego M _r /M _N	M _{max} MN	Moment bezwładności J [kgm ²]	Masa [kg]
	[kW]	[KM]		230 V Δ	400 V Y								
Frame size	Rated output		Rated speed [min ⁻¹]	Rated current [A] at		Efficiency η [%]	Power factor $\cos \varphi_N$	Torque T _N [Nm]	Starting current/ rated current I _L /I _N	Starting torque/ rated torque T _L /T _N	T _b T _N	Moment of inertia J [kgm ²]	Motor weight [kg]
	[kW]	[HP]		230 V Δ	400 V Y								

Silniki 2-biegunowe, 3000 min⁻¹; 50Hz

2-pole motors, 3000 min⁻¹; 50Hz

Sh 71-2A	0,37	0,50	2800	1,73	1,00	71	0,77	1,26	4,4	2,2	2,2	0,00039	5,0
Sh 71-2B	0,55	0,75	2790	2,35	1,35	75	0,82	1,88	4,0	2,0	2,1	0,00048	6,0
2SIE 71x-2C	0,75	1,00	2780	3,10	1,80	78	0,81	2,57	4,8	2,1	2,2	0,000691	7,6

Silniki 4-biegunowe, 1500 min⁻¹; 50Hz

4-pole motors, 1500 min⁻¹; 50Hz

Sh 71-4A	0,25	0,33	1380	1,50	0,85	66	0,64	1,73	3,0	2,0	2,0	0,00061	4,8
Sh 71-4B	0,37	0,50	1370	2,20	1,25	68	0,68	2,59	3,1	2,1	2,1	0,00077	5,9
Sh 71x-4C	0,55	0,75	1360	3,50	2,00	70	0,62	3,86	3,0	2,5	2,4	0,001099	7,2

Silniki 6-biegunowe, 1000 min⁻¹; 50Hz

6-pole motors, 1000 min⁻¹; 50Hz

Sh 71-6A	0,18	0,25	890	1,30	0,75	57	0,68	1,91	2,6	1,9	1,9	0,000736	4,8
Sh 71-6B	0,25	0,33	860	1,75	1,00	55	0,79	2,78	2,0	1,6	1,6	0,000946	5,8
Sh 71x-6C	0,37	0,50	880	2,35	1,35	60	0,70	4,02	2,6	1,9	1,8	0,001221	7,3

Silniki 8-biegunowe, 750 min⁻¹; 50Hz

8-pole motors, 750 min⁻¹; 50Hz

Sh 71-8A	0,09	0,12	680	1,15	0,65	35	0,59	1,26	1,9	1,9	1,9	0,000736	4,9
Sh 71-8B	0,12	0,17	670	1,25	0,70	47	0,63	1,71	1,9	1,7	1,8	0,000946	5,8
Sh 71x-8C	0,18	0,25	680	2,40	1,40	45	0,52	2,53	2,0	2,7	2,6	0,001221	7,3

Silniki odpowiadają wymaganiom normy IEC 60034-30.

Motors meet requirements of Standard IEC 60034-30.

Silniki mogą być wykonane i certyfikowane na zgodność z wymogami normy UL 1004 lub CSA C22.2 No 100-04.

Motors may be certified for safety that they are manufactured according to the requirements of the UL 1004 or CSA C22.2 No 100-04.

Silniki odpowiadają wymaganiom Polskiej Normy PN-EN 60034-1 oraz normom międzynarodowym IEC 60034-1.

Motors meet requirements of Polish Standard PN-EN 60034-1 and the international rules IEC 60034-1.

Wszystkie silniki posiadają znak CE.

All motors are provided with CE mark.

Silniki na łapach
Forma wykonania
IMB3

Foot - mounted motors
Type of construction
IMB3

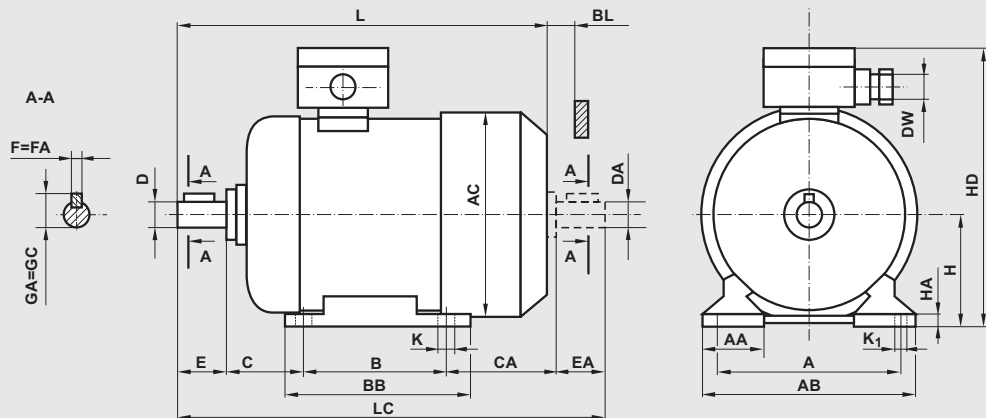

Forma wykonania IMB3

Type of construction IMB3

Typ Frame size	Wymiary (mm)																Dimensions (mm)				Łożyska Bearings	
	A	B	C	CA	D=DA	E=EA	F=FA	GA=GC	H	K	K ₁	DW	AA	AB	AC	BB	BL _{min}	HA	HD	L		LC
Sh 71-A				65																223	261	6203 2Z
Sh 71-B	112	90	45	88	14j6	30	5h9	16	71 _{0,5}	7	10	M20	45	142	141	116	12	8	182	245	283	
(2SIE)Sh 71x-C				106																263	301	

Silniki kołnierzowe
Formy wykonania
IMB5, IMB14

Flange
- mounted motors
Types of construction
IMB5, IMB14

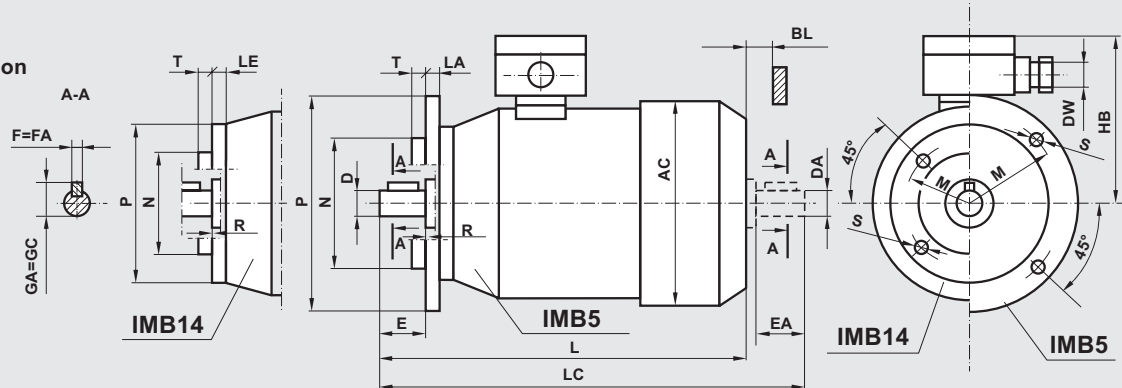

Forma wykonania IMB5

Type of construction IMB5

Typ Frame size	Wymiary (mm)										Dimensions (mm)							Łożyska Bearings	
	Kołnierz Flange	P	M	N	S	D=DA	E=EA	F=FA	GA=GC	LA	T	R	DW	AC	BL _{min}	HB	L		LC
SKh 71-A																	223	261	6203 2Z
SKh 71-B	B5	160	130	110j6	10	14j6	30	5h9	16	9	3,5	0	M20	141	12	111	245	283	
(2SIEK)SKh 71x-C																	263	301	

Forma wykonania IMB14

Type of construction IMB14

Typ Frame size	Wymiary (mm)										Dimensions (mm)							Łożyska Bearings	
	Kołnierz Flange	P	M	N	S	D=DA	E=EA	F=FA	GA=GC	LE	T	R	DW	AC	BL _{min}	HB	L		LC
SKh 71-A1	B14/1	140	115	95j6	M8	14j6	30	5h9	16	14	3	0	M20	141	12	111	223	261	6203 2Z
SKh 71-A2	B14/2	105	85	70j6	M6					12	2,5								
SKh 71-B1	B14/1	140	115	95j6	M8					14	3								
SKh 71-B2	B14/2	105	85	70j6	M6					12	2,5								
(2SIEK)SKh 71x-C1	B14/1	140	115	95j6	M8					14	3								
(2SIEK)SKh 71x-C2	B14/2	105	85	70j6	M6					12	2,5								

Producent zastrzega sobie możliwość zmian danych zawartych w karcie katalogowej wynikających z ciągłego doskonalenia wyrobu.

As part of our development program, we reserve the right to alter or amend any of the specifications without giving prior notice.



BESEL S.A.

FABRYKA SILNIKÓW ELEKTRYCZNYCH

SILNIKI INDUKCYJNE TRÓJFAZOWE serii h O WZNIOSIE OSI WAŁU 80 w tym SILNIKI ENERGOOSZCZĘDNE 2SIE klasy IE2

Charakterystyka silników katalogowych:

- silniki ogólnego przeznaczenia do pracy w warunkach klimatu umiarkowanego,
- praca ciągła S1,
- napięcia znamionowe 230V/400V (Δ/Y),
- częstotliwość zasilania 50 Hz,
- temperatura otoczenia od -15°C do $+40^{\circ}\text{C}$,
- kolor malowania RAL 5010.



THREE-PHASE INDUCTION MOTORS series h FRAME SIZE 80 including ENERGY EFFICIENT MOTORS 2SIE class IE2

Description of the catalogue motors:

- general purpose motors; temperate climate,
- duty S1,
- rated voltage 230V/400V (Δ/Y),
- frequency 50 Hz,
- ambient temperature from -15°C to $+40^{\circ}\text{C}$,
- standard paint colour RAL 5010.

stopień ochrony: IP54 (IP55; IP56; IP 65; IP 66)
klasa izolacji F (klasa H na życzenie)

degree of protection: IP54 (IP55; IP56; IP 65; IP 66)
insulation class F (class H on request)

Typ	Moc		Prędkość obrotowa [min ⁻¹]	Prąd [A] przy		Sprawność η [%]	Współczynnik mocy $\cos \varphi_N$	Moment znamionowy M_N [Nm]	Krotność prądu rozruchowego I_r/I_N	Krotność momentu rozruchowego M_r/M_N	$\frac{M_{max}}{M_N}$	Moment bezwładności J [kgm ²]	Masa [kg]
	[kW]	[KM]		230 V Δ	400 V Y								
Frame size	Rated output		Rated speed [min ⁻¹]	Rated current [A] at		Efficiency η [%]	Power factor $\cos \varphi_N$	Torque T_N [Nm]	Starting current/ rated current I_L/I_N	Starting torque/ rated torque T_L/T_N	$\frac{T_b}{T_N}$	Moment of inertia J [kgm ²]	Motor weight [kg]
	[kW]	[HP]		230 V Δ	400 V Y								

Silniki 2-biegunowe, 3000 min⁻¹; 50Hz

2-pole motors, 3000 min⁻¹; 50Hz

2SIE 80-2A	0,75	1,00	2840	3,30	1,90	79	0,74	2,52	5,0	3,2	3,0	0,000800	8,5
2SIE 80-2B	1,10	1,50	2840	4,80	2,70	80	0,75	3,70	5,5	3,4	3,4	0,001110	9,8
2SIE 80x-2C	1,50	2,00	2820	5,70	3,30	81,3	0,82	5,07	5,0	2,8	2,8	0,001450	12,0

Silniki 4-biegunowe, 1500 min⁻¹; 50Hz

4-pole motors, 1500 min⁻¹; 50Hz

Sh 80-4A	0,55	0,75	1400	2,70	1,60	72	0,71	3,75	3,6	2,0	2,1	0,001578	7,5
2SIE 80-4B	0,75	1,00	1400	3,70	2,20	80	0,65	5,12	4,2	3,1	3,2	0,002089	9,6
2SIE 80x-4C	1,10	1,50	1380	5,20	3,00	81,4	0,65	7,61	3,7	2,3	2,1	0,002680	11,5

Silniki 6-biegunowe, 1000 min⁻¹; 50Hz

6-pole motors, 1000 min⁻¹; 50Hz

Sh 80-6A	0,37	0,50	910	2,40	1,40	64	0,65	3,88	3,0	2,0	2,1	0,001693	7,4
Sh 80-6B	0,55	0,75	900	3,10	1,80	67	0,70	5,84	2,7	1,9	2,0	0,002070	8,6

Silniki 8-biegunowe, 750 min⁻¹; 50Hz

8-pole motors, 750 min⁻¹; 50Hz

Sh 80-8A	0,18	0,25	680	1,55	0,90	53	0,57	2,53	2,3	1,8	2,0	0,001693	7,5
Sh 80-8B	0,25	0,33	680	2,10	1,20	57	0,60	3,51	2,5	1,7	1,7	0,002070	8,9
Sh 80x-8C	0,37	0,50	680	2,95	1,70	58	0,60	5,20	2,5	2,0	2,0	0,001693	7,5
Sh 80x-8D	0,55	0,75	690	4,20	2,40	59	0,60	7,60	2,5	2,1	2,2	0,003451	12,7

Silniki odpowiadają wymaganiom normy IEC 60034-30.

Motors meet requirements of Standard IEC 60034-30.

Silniki mogą być wykonane i certyfikowane na zgodność z wymogami normy UL 1004 lub CSA C22.2 No 100-04.

Motors may be certified for safety that they are manufactured according to the requirements of the UL 1004 or CSA C22.2 No 100-04.

Silniki odpowiadają wymaganiom Polskiej Normy PN-EN 60034-1 oraz normom międzynarodowym IEC 60034-1.

Motors meet requirements of Polish Standard PN-EN 60034-1 and the international rules IEC 60034-1.

Wszystkie silniki posiadają znak CE.

All motors are provided with CE mark.

Silniki na łapach
Forma wykonania
IMB3

Foot - mounted motors
Type of construction
IMB3

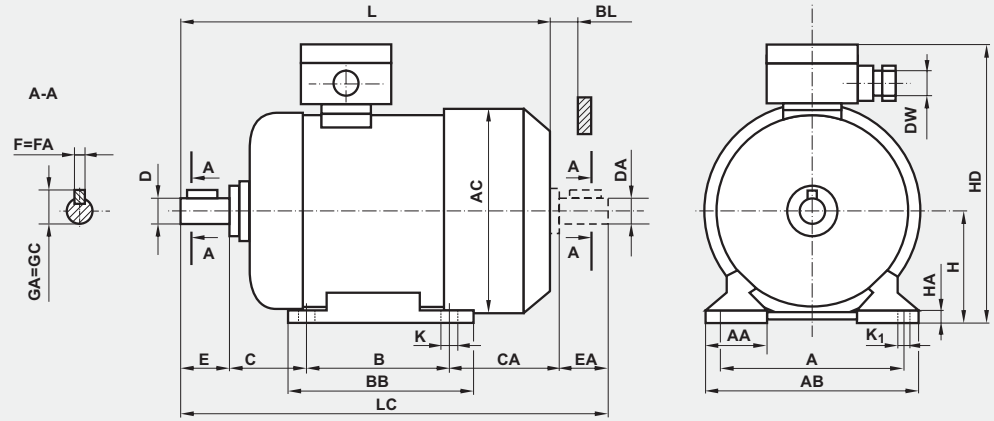

Forma wykonania IMB3

Type of construction IMB3

Typ Frame size	Wymiary (mm)																Dimensions (mm)				Łożyska Bearings	
	A	B	C	CA	D=DA	E=EA	F=FA	GA=GC	H	K	K ₁	DW	AA	AB	AC	BB	BL _{min}	HA	HD	L		LC
(2SIE)Sh 80-A	125	100	50	87	19j6	40	6h9	21,5	80-0,5	10	13	M20	55	160	157	130	15	9	200	266	317	6204 2Z
(2SIE)Sh 80-B				99																278	329	
(2SIE)Sh 80x-C				120																306	357	
(2SIE)Sh 80x-D				138																318	369	

Silniki kołnierzone
Formy wykonania
IMB5, IMB14

Flange - mounted motors
Types of construction
IMB5, IMB14

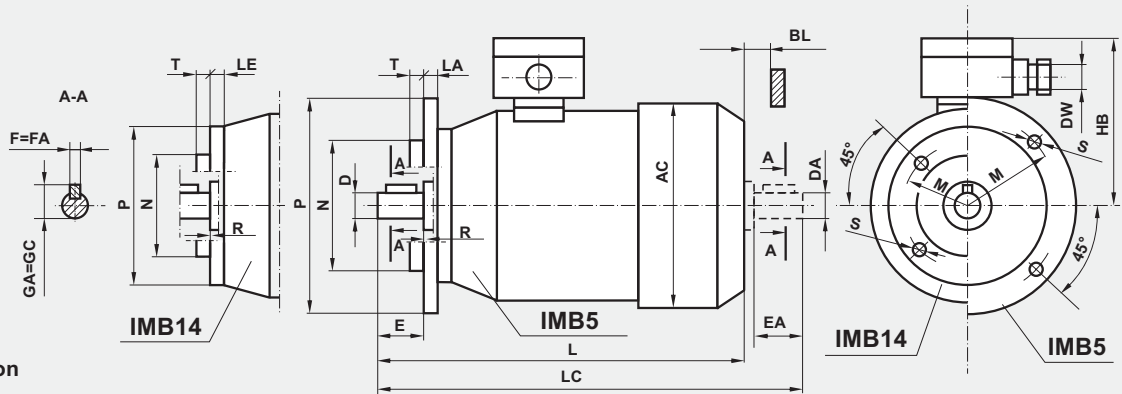

Forma wykonania IMB5

Type of construction IMB5

Typ Frame size	Wymiary (mm)										Dimensions (mm)							Łożyska Bearings	
	Kolnierz Flange	P	M	N	S	D=DA	E=EA	F=FA	GA=GC	LA	T	R	DW	AC	BL _{min}	HB	L		LC
(2SIEK)SKh 80-A	B5	200	165	130j6	12	19j6	40	6h9	21,5	10	3,5	0	M20	157	15	120	266	317	6204 2Z
(2SIEK)SKh 80-B																	278	329	
(2SIEK)SKh 80x-C																	306	357	
(2SIEK)SKh 80x-D																	318	369	

Forma wykonania IMB14

Type of construction IMB14

Typ Frame size	Wymiary (mm)										Dimensions (mm)							Łożyska Bearings	
	Kolnierz Flange	P	M	N	S	D=DA	E=EA	F=FA	GA=GC	LE	T	R	DW	AC	BL _{min}	HB	L		LC
(2SIEK)SKh 80-A1	B14/1	160	130	110j6	M8	19j6	40	6h9	21,5	14	3,5	0	M20	157	15	120	266	317	6204 2Z
(2SIEK)SKh 80-A2	B14/2	120	100	80j6	M6					12	3						278	329	
(2SIEK)SKh 80-B1	B14/1	160	130	110j6	M8					14	3,5						306	357	
(2SIEK)SKh 80-B2	B14/2	120	100	80j6	M6					12	3						318	369	
(2SIEK)SKh 80x-C1	B14/1	160	130	110j6	M8					14	3,5								
(2SIEK)SKh 80x-C2	B14/2	120	100	80j6	M6					12	3								
(2SIEK)SKh 80x-D1	B14/1	160	130	110j6	M8					14	3,5								
(2SIEK)SKh 80x-D2	B14/2	120	100	80j6	M6					12	3								



BESEL S.A.

FABRYKA SILNIKÓW ELEKTRYCZNYCH

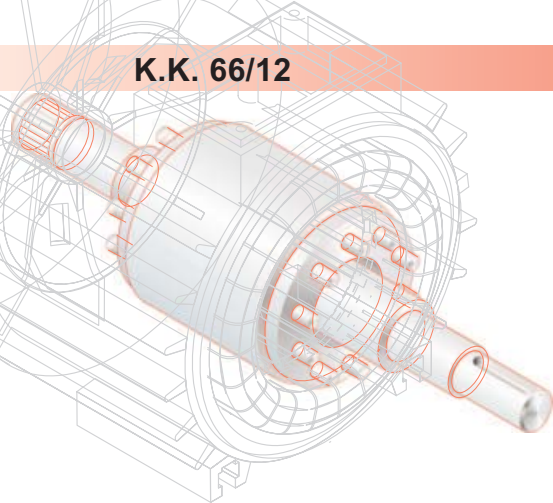

SILNIKI INDUKCYJNE TRÓJFAZOWE serii h O WZNIOSIE OSI WAŁU 90 w tym SILNIKI ENERGOOSZCZĘDNE klasy IE2

Charakterystyka silników katalogowych:

- silniki ogólnego przeznaczenia do pracy w warunkach klimatu umiarkowanego,
- praca ciągła S1,
- napięcia znamionowe 230V/400V (Δ/Y),
- częstotliwość zasilania 50 Hz,
- temperatura otoczenia od -15°C do $+40^{\circ}\text{C}$,
- kolor malowania RAL 5010.

THREE-PHASE INDUCTION MOTORS series h FRAME SIZE 90 including ENERGY EFFICIENT MOTORS class IE2

Description of the catalogue motors:

- general purpose motors; temperate climate,
- duty S1,
- rated voltage 230V/400V (Δ/Y),
- frequency 50 Hz,
- ambient temperature from -15°C to $+40^{\circ}\text{C}$,
- standard paint colour RAL 5010.

stopień ochrony: IP54 (IP55; IP56; IP 65; IP 66)
klasa izolacji F (klasa H na życzenie)

degree of protection: IP54 (IP55; IP56; IP 65; IP 66)
insulation class F (class H on request)

Typ	Moc		Prędkość obrotowa [min ⁻¹]	Prąd [A] przy		Sprawność η [%]	Współczynnik mocy $\cos \varphi_N$	Moment znamionowy M_N [Nm]	Krotność prądu rozruchowego I_r/I_N	Krotność momentu rozruchowego M_r/M_N	$\frac{M_{max}}{M_N}$	Moment bezwładności J [kgm ²]	Masa [kg]
	[kW]	[KM]		230 V Δ	400 V Y								
Frame size	Rated output		Rated speed [min ⁻¹]	Rated current [A] at		Efficiency η [%]	Power factor $\cos \varphi_N$	Torque T_N [Nm]	Starting current/ rated current I_L/I_N	Starting torque/ rated torque T_L/T_N	$\frac{T_b}{T_N}$	Moment of inertia J [kgm ²]	Motor weight [kg]
	[kW]	[HP]		230 V Δ	400 V Y								

Silniki 2-biegunowe, 3000 min⁻¹; 50Hz

2-pole motors, 3000 min⁻¹; 50Hz

Sh 90-2S/IE2	1,50	2,00	2820	5,70	3,30	81,3	0,82	5,07	5,0	2,8	2,8	0,001450	12
--------------	------	------	------	------	------	------	------	------	-----	-----	-----	----------	----

Silniki 4-biegunowe, 1500 min⁻¹; 50Hz

4-pole motors, 1500 min⁻¹; 50Hz

Sh 90-4S/IE2	1,10	1,50	1380	5,20	3,00	81,4	0,65	7,61	3,7	2,3	2,1	0,002680	11,5
--------------	------	------	------	------	------	------	------	------	-----	-----	-----	----------	------

Silniki 8-biegunowe, 750 min⁻¹; 50Hz

8-pole motors, 750 min⁻¹; 50Hz

Sh 90-8S	0,37	0,50	680	2,95	1,70	58	0,60	5,20	2,5	2,0	2,0	0,0024	11,0
Sh 90-8L	0,55	0,75	690	4,20	2,40	59	0,60	7,60	2,5	2,1	2,2	0,0032	12,7

Silniki odpowiadają wymaganiom normy IEC 60034-30.

Motors meet requirements of Standard IEC 60034-30.

Silniki mogą być wykonane i certyfikowane na zgodność z wymogami normy UL 1004 lub CSA C22.2 No 100-04.

Motors may be certified for safety that they are manufactured according to the requirements of the UL 1004 or CSA C22.2 No 100-04.

Silniki odpowiadają wymaganiom Polskiej Normy PN-EN 60034-1 oraz normom międzynarodowym IEC 60034-1.

Motors meet requirements of Polish Standard PN-EN 60034-1 and the international rules IEC 60034-1.

Wszystkie silniki posiadają znak CE.

All motors are provided with CE mark.

Silniki na łapach
Forma wykonania
IMB3

Foot - mounted motors
Type of construction
IMB3

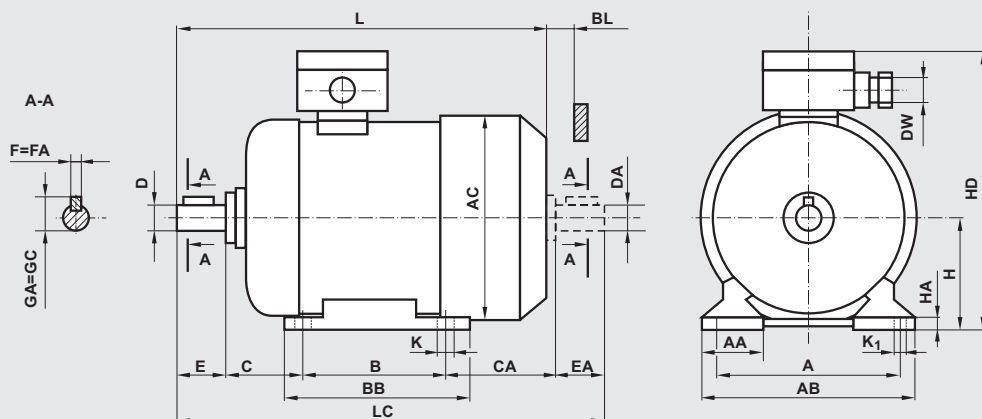

Forma wykonania IMB3

Type of construction IMB3

Typ	Wymiary (mm)																Dimensions (mm)				Łożyska			
	Frame size	A	B	C	CA	D=DA	E=EA	F=FA	GA=GC	H	K	K ₁	DW	AA	AB	AC	BB	BL _{min}	HA	HD	L	LC	Bearings	
		P	N																					
Sh 90-S (IE2)	140	100	56	114	24j6	50	8h9	27	90 _{-0,5}	10	13	M20	60	170	157	153	15	12	208	316	376	6204 2Z	6205 2Z	
Sh 90-L		125		107																328	388			

Silniki kołnierkowe
Formy wykonania
IMB5, IMB14

Flange - mounted motors
Types of construction
IMB5, IMB14

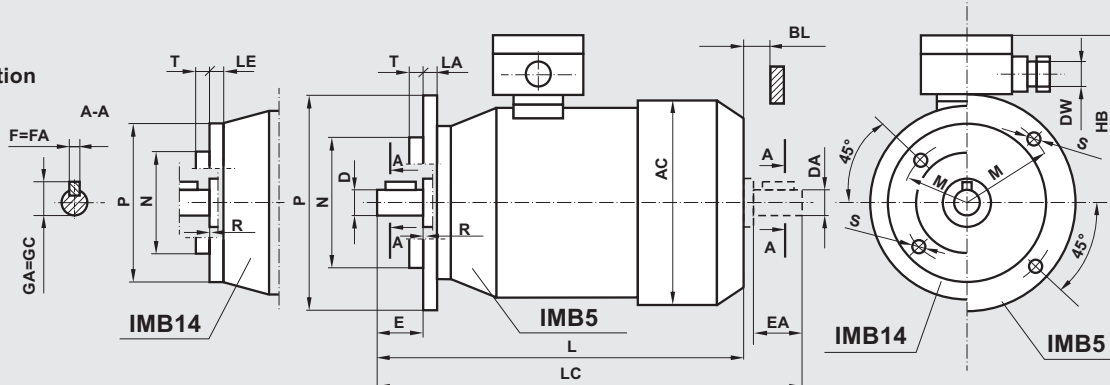

Forma wykonania IMB5

Type of construction IMB5

Typ	Wymiary (mm)											Dimensions (mm)						Łożyska		
	Kołnierz Flange	P	M	N	S	D=DA	E=EA	F=FA	GA=GC	LA	T	R	DW	AC	BL _{min}	HB	L	LC	Bearings	
		P	N																	
SKh 90-S (IE2)	B5	200	165	130j6	12	24j6	50	8h9	27	10	3,5	0	M20	157	15	118	316	376	6204 2Z	6205 2Z
SKh 90-L																	328	388		

Forma wykonania IMB14

Type of construction IMB14

Typ	Wymiary (mm)											Dimensions (mm)						Łożyska		
	Kołnierz Flange	P	M	N	S	D=DA	E=EA	F=FA	GA=GC	LE	T	R	DW	AC	BL _{min}	HB	L	LC	Bearings	
		P	N																	
SKh 90-S1 (IE2)	B14/1	160	130	110j6	M8	24j6	50	8h9	27	10	3,5	0	M20	157	15	118	316	376	6204 2Z	6205 2Z
SKh 90-S2 (IE2)	B14/2	140	115	95j6	M8					10	3									
SKh 90-L1	B14/1	160	130	110j6	M8					10	3,5									
SKh 90-L2	B14/2	140	115	95j6	M8					10	3									

Producent zastrzega sobie możliwość zmian danych zawartych w karcie katalogowej wynikających z ciągłego doskonalenia wyrobu.

As part of our development program, we reserve the right to alter or amend any of the specifications without giving prior notice.