

**TRÓJFAZOWE SILNIKI INDUKCYJNE KLATKOWE  
PRZECIWWYBUCHOWE Z OSŁONĄ OGNIOSZCZELNĄ  
SERII dSg 160÷315**

**THREE-PHASE SQUIRREL-CAGE INDUCTION MOTORS  
EXPLOSION-PROOF WITH FLAMEPROOF ENCLOSURE  
SERIES dSg 160÷315**

## SILNIKI PRZECIWWYBUCHOWE

## EXPLOSION-PROOF MOTORS

### Zastosowanie:

- miejsce pracy: w kopalniach zagrożonych wybuchem metanu i pyłu węglowego
- w pomieszczeniach i przestrzeniach w których mogą powstawać mieszaniny wybuchowe palnych gazów i par cieczy z powietrzem zaliczane do grupy IIA, klas temperatury T1 ÷ T5
- otoczenie: w środowisku o stopniu agresywności C zgodnie z PN-71/H-04651

### Charakterystyka wykonania:

- praca ciągła S1
- napięcie znamionowe 500 lub 1000 [V],
- częstotliwość napięcia zasilania 50 [Hz],
- temperatura otoczenia od -20 do +40 [°C],
- izolacja klasy F (155°C),
- stopień ochrony IP 55,
- zabezpieczenia termiczne uzwojeń i łożysk (czujniki bimetalowe)
- skrzynka zaciskowa z jednym wpustem kablowym wyposażona w: 3 zaciski prądowe, 2 ÷ 4 zaciski pomocnicze, zacisk do przyłączenia przewodu ochronnego, człon końcowy CK1
- urządzenie kategorii M2, 2G wg Dyrektywy 94/9/WE (ATEX)

### Silniki spełniają wymagania norm:

- PN-EN 60034-1 - Maszyny elektryczne wirujące Część 1: Dane znamionowe i parametry,
- PN-EN-60079-0 - Atmosfery wybuchowe - Część 0: Urządzenia - Podstawowe wymagania
- PN-EN-60079-1 - Atmosfery wybuchowe Część 1: Zabezpieczenie urządzeń za pomocą osłon ognioszczelnych "d".
- PN-G-38010:1997 - (dla wykonań na napięcie do 1000V)

### Wykonania na życzenia:

- napięcie zasilania do 1250 [V]
- częstotliwość napięcia zasilania 60 [Hz],
- na dwa napięcia zasilania z możliwością przełączania 500 / 1000 [V]
- zabezpieczenia termiczne uzwojeń i/lub łożysk (termistory PTC lub termorezystory Pt100)
- **stopień** ochrony IP 56,
- skrzynka zaciskowa wyposażona w: maksymalnie 4 wpusty kablowe, 6 zacisków prądowych, człon CK2
- przystosowane do zasilania z przetwornic częstotliwości
- z certyfikatem EAC wg GOST
- inne wykonania specjalne wg wymagań Klienta (szczegóły wykonania oraz termin realizacji muszą być uzgodnione indywidualnie).

### Sposób zamawiania:

- W zamówieniu należy podać pełne określenie typu silnika, moc, prędkość obrotową, napięcie zasilające, układ połączeń, częstotliwość, formę wykonania oraz inne szczegóły nie katalogowego lub specjalnego wykonania.

Wszystkie silniki posiadają znak CE.



**IM2 Ex d I Mb**  
**II 2G Ex d IIA T5 Gb** <sup>1)</sup>

<sup>1)</sup> T4 – wielkość mechaniczna 315

### Application:

- operation place: in mines threatened an explosion of the methane and the coal dust
- in spaces (zones 1 or 2) in which can come into being explosive mixtures of combustible gases and steams of liquid with air reckoned groups I and IIA, classes of the temperature T1 ÷ T5
- environment: in environment with degree of the aggressiveness C acc. PN-71/H-04651

### Features:

- operating duty S1
- rated voltage 500 V or 1000 [V],
- frequency 50 [Hz],
- ambient temperature -20 to +40 [°C],
- insulation class F (155°C),
- degree of protection IP 55,
- thermal protection of the stator's winding and bearings (bimetal sensors),
- terminal box with one cable inlet equipped with: 3 current terminals, 2 ÷ 4 auxiliary terminals, terminal for connect of PE wire, terminal unit CK1 for control PE wire
- the device of the category M2 acc. to Directive 94/9/EC (ATEX)

### Motors meet requirements of standards:

- PN-EN 60034-1 - Rotating electrical machines Part 1: Rating and performance,
- IEC 60079-0 - Explosive atmospheres – Part 0: Equipment – General requirements
- IEC 60079-1 - Explosive atmospheres – Part 1: Security devices using flameproof enclosure "d"
- PN-G-38010:1997 – (for the performances on the voltage to 1000V)

### Features on request:

- the supply voltage to 1250 [V]
- frequency 60 Hz
- for double voltage with the possibility of switching 500 / 1000 [V]
- with temperature sensors in stator's winding and/or bearing (PTC or Pt100)
- degree of protection IP 56,
- terminal box with max 4 cable inlets: 6 current terminals, terminal unit CK2
- adapted for frequency converter supply
- with EAC certification according to GOST
- other non-standard execution according to Client requirements (design details and delivery time are to be individual agreed).

### How to order:

- In the order there must be clearly given: full designation of the motor, rated output, rated speed, rated voltage, phase connection, frequency, mounting form and all other details for non catalogue execution.

All motors are provided with CE mark.



**PB Ex d I Mb**  
**1 Ex d IIA T5 Gb** <sup>1)</sup>

<sup>1)</sup> T4 – frame 315

**PARAMETRY EKSPLOATACYJNE SILNIKÓW**  
**PERFORMANCES OF MOTORS**

Wielkość Mechaniczna Frame	Moc Znamionowa Rated output		Prędkość Znamionowa Rated speed	Dane przy obciążeniu znamionowym Parameters at rated output				Krotności Ratio of			Moment bezwładności Moment of inertia	Masa Weight IM B3	
	P <sub>N</sub>			Sprawność Efficiency $\eta_N$	Współczynnik Mocy Power factor $\cos \varphi$	Prąd Current		Moment Torque T <sub>N</sub>	Momentu rozruchowego Starting torque T <sub>i</sub> /T <sub>N</sub>	Momentu maksymalnego Maximum torque T <sub>b</sub> /T <sub>N</sub>			Prądu Rozruchowego Starting current I <sub>i</sub> /I <sub>N</sub>
	[kW]	[HP]	[%]			[A]	[A]				[Nm]	[-]	
			[min <sup>-1</sup> ]			I <sub>N(500V)</sub>	I <sub>N(1000V)</sub>					[kgm <sup>2</sup> ]	[kg]
2p=2 3000 obr/min													
dSg 160M2A-EP	11	15	2925	88,5	0,89	16,1	8,1	36	2,1	2,5	5,7	0,04	145
dSg 160M2B-EP	15	20	2920	89,5	0,91	21,3	10,6	49	2,1	2,2	6,0	0,05	155
dSg 160L2-EP	18,5	25	2925	91,3	0,90	26	13	60	2,4	2,8	6,5	0,06	175
dSg 180M2-EP	22	30	2945	91,5	0,89	31	15,6	71	2,7	2,6	6,8	0,07	210
dSg 200L2A-EP	30	40	2960	92,9	0,89	42	20,9	97	1,9	2,3	6,0	0,15	300
dSg 200L2B-EP	37	50	2960	93,7	0,89	51	25,6	119	2,2	2,5	6,7	0,18	330
dSg 225M2-EP	45	60	2968	94,5	0,89	62	31	145	2,4	2,5	7,0	0,26	390
dSg 250M2-EP	55	75	2970	93,5	0,90	75	37,5	177	2,0	2,0	6,9	0,36	450
dSg 280S2-EP	75	100	2977	94,0	0,90	102	51	241	2,1	3,3	7,5	0,76	610
dSg 280M2-EP	90	125	2970	94,7	0,91	121	60	289	2,0	3,2	7,0	0,87	650
dSg 315S2-EP	110	150	2977	95,1	0,91	147	73	353	2,0	2,8	8,7	0,91	780
dSg 315M2A-EP	132	180	2975	95,0	0,91	176	88	424	2,1	2,8	8,5	0,98	820
dSg 315M2B-EP	160	220	2975	95,9	0,91	212	106	514	1,9	2,7	7,9	1,20	880
dSg 315L2-EP	200	272	2979	95,9	0,92	262	131	643	2,3	2,7	8,2	1,58	1055
2p=4 1500 obr/min													
dSg 160M4-EP	11	15	1463	89,5	0,84	16,9	8,4	72	2,5	2,9	7,5	0,06	155
dSg 160L4-EP	15	20	1460	89,8	0,86	22,4	11,2	98	2,5	3,2	7,9	0,08	170
dSg 180M4-EP	18,5	25	1465	90,8	0,90	26,1	13,1	121	2,3	2,9	6,9	0,11	205
dSg 180L4-EP	22	30	1465	91,5	0,90	31	15,4	143	2,5	2,9	7,2	0,13	225
dSg 200L4-EP	30	40	1472	92,5	0,88	42,5	21,3	195	2,9	2,5	7,1	0,31	315
dSg 225S4-EP	37	50	1475	92,6	0,88	52	26,2	240	2,1	2,2	6,3	0,44	365
dSg 225M4-EP	45	60	1480	94,0	0,88	63	31,5	290	2,4	2,3	7,0	0,53	405
dSg 250M4-EP	55	75	1483	93,5	0,91	75	37,5	354	2,4	2,6	7,3	0,79	485
dSg 280S4-EP	75	100	1485	94,2	0,90	102	51	482	2,5	2,5	7,3	1,37	660
dSg 280M4-EP	90	125	1485	94,8	0,91	120	60	579	2,6	2,6	7,3	1,63	700
dSg 315S4-EP	110	150	1480	94,2	0,92	147	73	710	2,3	2,2	6,9	1,67	810
dSg 315M4A-EP	132	180	1487	94,9	0,90	178	89	848	2,3	2,5	7,6	1,84	850
dSg 315M4B-EP	160	220	1489	95,4	0,86	225	113	1026	2,7	2,4	8,5	2,27	890
dSg 315L4-EP	200	272	1485	95,7	0,90	268	134	1286	2,2	2,0	7,4	2,46	1040
2p=6 1000 obr/min													
dSg 160M6-EP	7,5	10	962	87,5	0,81	12,2	6,1	74	2,2	3,0	6,4	0,07	145
dSg 160L6-EP	11	15	960	88,2	0,82	17,6	8,8	109	2,2	2,8	6,7	0,10	170
dSg 180L6-EP	15	20	973	89,0	0,85	22,9	11,4	147	2,4	2,4	5,6	0,19	215
dSg 200L6A-EP	18,5	25	980	90,5	0,86	27,4	13,7	180	2,5	2,4	6,8	0,41	300
dSg 200L6B-EP	22	30	981	90,5	0,88	32	15,9	214	2,4	2,2	6,9	0,47	315
dSg 225M6-EP	30	40	982	91,9	0,88	43	21,4	292	2,1	2,2	6,3	0,76	380
dSg 250M6-EP	37	50	985	92,5	0,89	52	25,9	359	2,6	2,3	6,8	1,23	475
dSg 280S6-EP	45	60	985	93,0	0,87	64	32	436	2,0	2,3	6,5	1,35	585
dSg 280M6-EP	55	75	985	93,5	0,89	76	38	533	2,2	2,2	6,2	1,61	630
dSg 315S6-EP	75	100	985	93,5	0,89	104	52	727	2,3	2,2	6,6	2,16	810
dSg 315M6A-EP	90	125	984	93,7	0,88	126	63	873	2,5	2,0	6,8	2,29	840
dSg 315M6B-EP	110	150	985	94,2	0,89	152	76	1066	2,3	2,1	7,2	2,86	925
2p=8 750 obr/min													
dSg 160M8A-EP	4	5,5	710	81,0	0,75	7,6	3,8	54	2,1	2,7	5,1	0,06	130
dSg 160M8B-EP	5,5	7,5	705	82,5	0,75	10,3	5,1	74	2,5	3,1	5,5	0,08	140
dSg 160L8-EP	7,5	10	708	83,5	0,78	13,3	6,6	101	2,7	3,0	5,7	0,10	160
dSg 180L8-EP	11	15	730	88,5	0,76	18,9	9,4	144	1,9	2,5	5,5	0,19	215
dSg 200L8-EP	15	20	733	89,5	0,83	23,3	11,7	195	2,2	2,1	5,5	0,45	305
dSg 225S8-EP	18,5	25	735	89,5	0,81	29,5	14,7	240	2,0	2,0	5,6	0,58	335
dSg 225M8-EP	22	30	735	90,4	0,80	35	17,6	286	2,0	1,8	5,2	0,68	365
dSg 250M8-EP	30	40	738	91,5	0,84	45	22,5	388	2,5	2,1	6,3	1,27	470
dSg 280S8-EP	37	50	737	92,8	0,83	55	27,7	479	2,0	1,8	5,3	1,47	605
dSg 280M8-EP	45	60	737	92,5	0,84	67	33,5	583	2,1	2,0	5,4	1,80	665
dSg 315S8-EP	55	75	735	92,7	0,81	85	42,5	715	2,0	1,9	5,3	2,16	810
dSg 315M8A-EP	75	100	737	93,2	0,82	113	57	972	2,5	1,9	6,2	2,29	835
dSg 315M8B-EP	90	125	737	93,2	0,82	136	68	1166	2,4	1,9	6,5	2,86	915

Wymiary silników na łapach

Dimensions of foot-mounted motors

dSg 160 ÷ 180 -EP

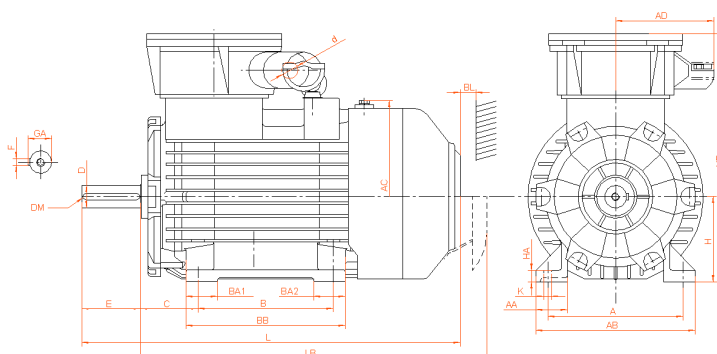

dSg 200 ÷ 315 -EP

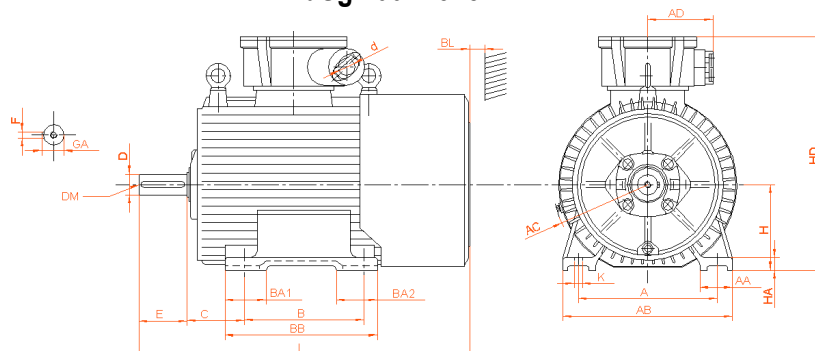

Wielkość Frame	A	B	C	DM	D <sub>m6</sub>	E	F <sub>h9</sub>	GA	H <sub>-0,5</sub>	HA	K	AA	AB	AC	AD	BA1	BA2	BB	HD	BL	L
dSg160M	254	210	108	M16	42 <sub>k6</sub>	110	12	45	160	22	15	60	300	360	185	60	60	256	475	60	670
dSg160L	254	254	108	M16	42 <sub>k6</sub>	110	12	45	160	22	15	60	300	360	185	60	60	300	475	60	710
dSg180M	279	241	121	M16	48 <sub>k6</sub>	110	14	51,5	180	22	15	65	330	400	185	65	105	330	515	65	765
dSg180L	279	279	121	M16	48 <sub>k6</sub>	110	14	51,5	180	22	15	65	330	400	185	65	105	330	515	65	765
dSg200L	318	305	133	M20	55	110	16	59	200	32	19	80	400	465	190	105	105	388	600	70	855
dSg225S	356	286	149	M20	60	140	18	64	225	34	19	85	445	510	190	115	120	385	645	75	905
dSg225M2	356	311	149	M20	55	110	16	59	225	34	19	85	445	510	190	115	120	385	645	75	875
dSg225M4+8	356	311	149	M20	60	140	18	64	225	34	19	85	445	510	190	115	120	385	645	75	905
dSg250M2	406	349	168	M20	60	140	18	64	250	37	24	95	495	550	190	120	120	445	690	85	965
dSg250M4+8	406	349	168	M20	65	140	18	69	250	37	24	95	495	550	190	120	120	445	690	85	965
dSg280S2	457	368	190	M20	65	140	18	69	280 <sub>-1</sub>	40	24	100	560	620	190	140	170	500	765	85	1115
dSg280S4+8	457	368	190	M20	75	140	20	79,5	280 <sub>-1</sub>	40	24	100	560	620	190	140	170	500	765	85	1115
dSg280M2	457	419	190	M20	65	140	18	69	280 <sub>-1</sub>	40	24	100	560	620	190	140	170	500	765	85	1115
dSg280M4+6	457	419	190	M20	75	140	20	79,5	280 <sub>-1</sub>	40	24	100	560	620	190	140	170	500	765	85	1115
dSg315S2	508	406	216	M20	65	140	18	69	315 <sub>-1</sub>	46	28	105	610	630	190	140	185	550	815	130	1260
dSg315S4+8	508	406	216	M20	80	170	22	85	315 <sub>-1</sub>	46	28	105	610	630	190	140	185	550	815	130	1290
dSg315M2	508	457	216	M20	65	140	18	69	315 <sub>-1</sub>	46	28	105	610	630	190	140	185	550	815	130	1260
dSg315M4+8	508	457	216	M20	80	170	22	85	315 <sub>-1</sub>	46	28	105	610	630	190	140	185	550	815	130	1290
dSg315L2	508	508	216	M20	65	140	18	69	315 <sub>-1</sub>	46	28	105	610	630	190	140	185	630	815	130	1340
dSg315L4	508	508	216	M20	80	170	22	85	315 <sub>-1</sub>	46	28	105	610	630	190	140	185	630	815	130	1370

Wymiary silników kołnierzowych

Dimensions of flange-mounted motors

dSKg 160 ÷ 180 -EP

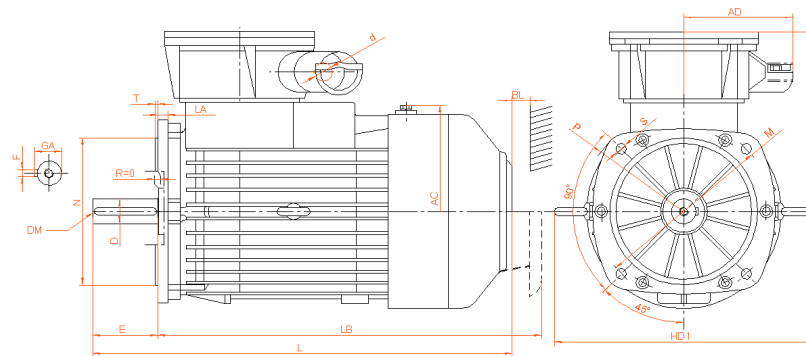

dSKg 200 ÷ 315 -EP

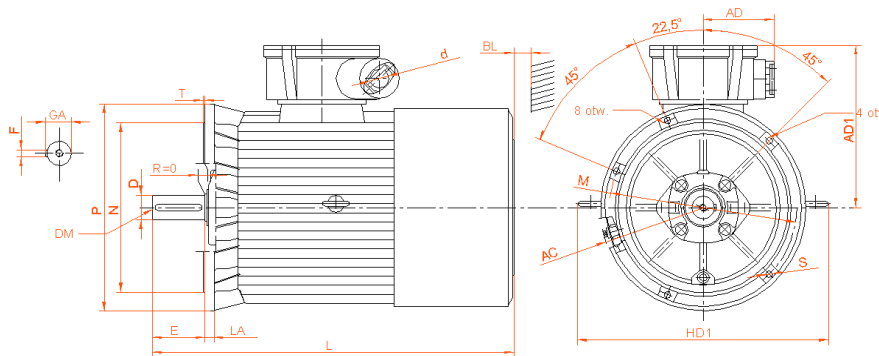

Wielkość Frame	D <sub>m6</sub>	DM	E	F <sub>h9</sub>	GA	H <sub>0.5</sub>	AC	AD1	LA	M±0,4	N <sub>j6</sub>	P	S		T	HD1	BL	L
													ø	Qty				
dSKg160 M	42 <sub>k6</sub>	M16	110	12	45	160	360	315	17	300	250	350	18	4	5	440	60	670
dSKg160 L	42 <sub>k6</sub>	M16	110	12	45	160	360	315	17	300	250	350	18	4	5	440	60	710
dSKg180 M	48 <sub>k6</sub>	M16	110	14	51,5	180	400	335	18	300	250	350	18	4	5	480	65	765
dSKg180 L	48 <sub>k6</sub>	M16	110	14	51,5	180	400	335	18	300	250	350	18	4	5	480	65	765
dSKg200L	55	M20	110	16	59	200	465	400	21	350	300	400	18	4	5	560	70	855
dSKg225S	60	M20	140	18	64	225	510	420	22	400	350	450	18	8	5	610	75	905
dSKg225M2	55	M20	110	16	59	225	510	420	22	400	350	450	18	8	5	610	75	875
dSKg225M4+8	60	M20	140	18	64	225	510	420	22	400	350	450	18	8	5	610	75	905
dSKg250M2	60	M20	140	18	64	250	550	440	24	500	450	550	18	8	5	670	85	965
dSKg250M4+8	65	M20	140	18	69	250	550	440	24	500	450	550	18	8	5	670	85	965
dSKg280S2	65	M20	140	18	69	280 <sub>-1</sub>	620	485	25	500	450	550	18	8	5	770	85	1115
dSKg280S4+8	75	M20	140	20	79,5	280 <sub>-1</sub>	620	485	25	500	450	550	18	8	5	770	85	1115
dSKg280M2	65	M20	140	18	69	280 <sub>-1</sub>	620	485	25	500	450	550	18	8	5	770	85	1115
dSKg280M4+6	75	M20	140	20	79,5	280 <sub>-1</sub>	620	485	25	500	450	550	18	8	5	770	85	1115
dSKg315S2	65	M20	140	18	69	315 <sub>-1</sub>	630	500	26	600	550 <sub>js6</sub>	660	22	8	6	770	130	1260
dSKg315S4+8	80	M20	170	22	85	315 <sub>-1</sub>	630	500	26	600	550 <sub>js6</sub>	660	22	8	6	770	130	1290
dSKg315M2	65	M20	140	18	69	315 <sub>-1</sub>	630	500	26	600	550 <sub>js6</sub>	660	22	8	6	770	130	1260
dSKg315M4+8	80	M20	170	22	85	315 <sub>-1</sub>	630	500	26	600	550 <sub>js6</sub>	660	22	8	6	770	130	1290
dSKg315L2	65	M20	140	18	69	315 <sub>-1</sub>	630	500	26	600	550 <sub>js6</sub>	660	22	8	6	770	130	1340
dSKg315L4	80	M20	170	22	85	315 <sub>-1</sub>	630	500	26	600	550 <sub>js6</sub>	660	22	8	6	770	130	1370

Wymiary silników kołnierzo-łapowych Dimensions of foot-flange mounted motors

dSLg 160 ÷ 180 -EP

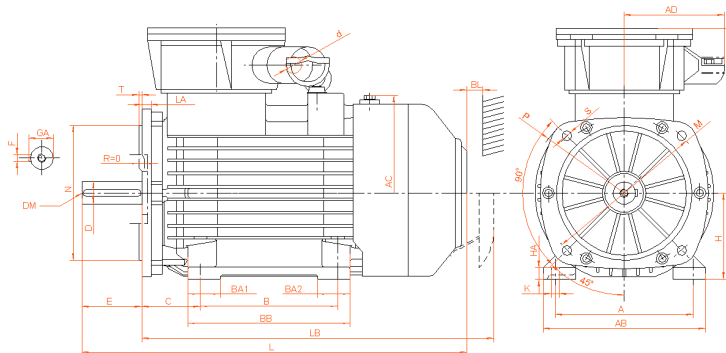

dSLg 200 ÷ 315 -EP

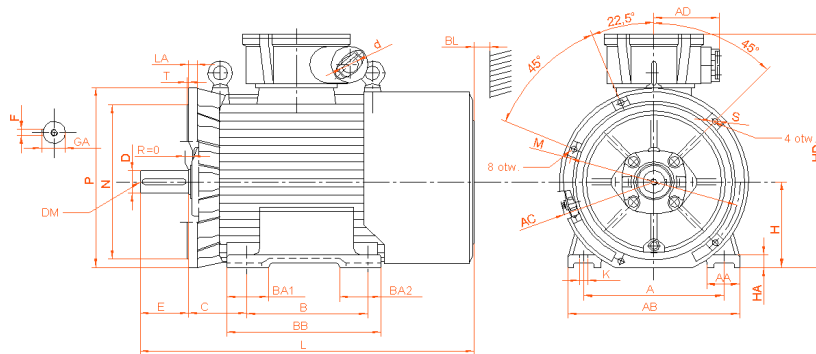

Wielkość Frame	A	B	C	D <sub>m6</sub>	DM	E	F <sub>h9</sub>	GA	H <sub>0.5</sub>	HA	K	AA	AB	BB	BA1	BA2	AC	HD	LA	M±0,4	N <sub>j6</sub>	P	S		T	BL	L
																							ø	Qty			
dSLg160M	254	210	108	42 <sub>k6</sub>	M16	110	12	45	160	22	15	60	300	256	60	60	360	475	17	300	250	350	18	4	5	60	670
dSLg160L	254	254	108	42 <sub>k6</sub>	M16	110	12	45	160	22	15	60	300	300	60	60	360	475	17	300	250	350	18	4	5	60	710
dSLg180M	279	241	121	48 <sub>k6</sub>	M16	110	14	51,5	180	22	15	65	330	330	65	105	400	515	18	300	250	350	18	4	5	65	765
dSLg180L	279	279	121	48 <sub>k6</sub>	M16	110	14	51,5	180	22	15	65	330	330	65	105	400	515	18	300	250	350	18	4	5	65	765
dSLg200L	318	305	133	55	M20	110	16	59	200	32	19	80	400	388	105	105	465	600	21	350	300	400	18	4	5	70	855
dSLg225S	356	286	149	60	M20	140	18	64	225	34	19	85	445	385	115	120	510	645	22	400	350	450	18	8	5	75	905
dSLg225M	356	311	149	55	M20	110	16	59	225	34	19	85	445	385	115	120	510	645	22	400	350	450	18	8	5	75	875
dSLg225M4+8	356	311	149	60	M20	140	18	64	225	34	19	85	445	385	115	120	510	645	22	400	350	450	18	8	5	75	905
dSLg250M2	406	349	168	60	M20	140	18	64	250	37	24	95	495	445	120	120	550	690	24	500	450	550	18	8	5	85	965
dSLg250M4+8	406	349	168	65	M20	140	18	69	250	37	24	95	495	445	120	120	550	690	24	500	450	550	18	8	5	85	965
dSLg280S2	457	368	190	65	M20	140	18	69	280,1	40	24	100	560	500	140	170	620	765	25	500	450	550	18	8	5	85	1115
dSLg280S4+8	457	368	190	75	M20	140	20	79,5	280,1	40	24	100	560	500	140	170	620	765	25	500	450	550	18	8	5	85	1115
dSLg280M2	457	419	190	65	M20	140	18	69	280,1	40	24	100	560	500	140	170	620	765	25	500	450	550	18	8	5	85	1115
dSLg280M4+6	457	419	190	75	M20	140	20	79,5	280,1	40	24	100	560	500	140	170	620	765	25	500	450	550	18	8	5	85	1115
dSLg315S2	508	406	216	65	M20	140	18	69	315,1	46	28	105	610	550	140	185	630	815	26	600	550 <sub>s6</sub>	660	22	8	6	130	1260
dSLg315S4+8	508	406	216	80	M20	170	22	85	315,1	46	28	105	610	550	140	185	630	815	26	600	550 <sub>s6</sub>	660	22	8	6	130	1290
dSLg315M2	508	457	216	65	M20	140	18	69	315,1	46	28	105	610	550	140	185	630	815	26	600	550 <sub>s6</sub>	660	22	8	6	130	1260
dSLg315M4+8	508	457	216	80	M20	170	22	85	315,1	46	28	105	610	550	140	185	630	815	26	600	550 <sub>s6</sub>	660	22	8	6	130	1290
dSLg315L2	508	508	216	65	M20	140	18	69	315,1	46	28	105	610	630	140	185	630	815	26	600	550 <sub>s6</sub>	660	22	8	6	130	1340
dSLg315L4	508	508	216	80	M20	170	22	85	315,1	46	28	105	610	630	140	185	630	815	26	600	550 <sub>s6</sub>	660	22	8	6	130	1370

**FORMY WYKONANIA WG PN-EN60034-7.  
MOUNTING ARRANGEMENTS ACCORDING TO IEC 60034-7**

	Walek poziomy Horizontal shaft			Walek pionowy Vertical shaft	
	Oznaczenie Marking			Oznaczenie Marking	
	System II	System I		System II	System I
	IM 1001 dSg 160...315	IM B3 dSg 160...315		IM 1011 dSg 160...315	IM V5 dSg 160...315
	IM 1051 dSg 160...280	IM B6 dSg 160...315		IM 1031 dSg 160...315	IM V6 dSg 160...315
	IM 1061 dSg 160...280	IM B7 dSg 160...315		IM 2011 dSLg 160...315	IM V15 dSLg 160...315
	IM 1071 dSg 160...315	IM B8 dSg 160...315		IM 2031 dSLg 160...315	IM V36 dSLg 160...315
	IM 2001 dSLg 160...315	IM B35 dSLg 160...315		IM 3011 dSKg 160,180,315 IM 4011 dSKg 200...280	IM V1 dSKg 160,180,315 IM 4011 dSKg 200...280
	IM 3001 dSKg 160,180,315 IM 4001 dSKg 200...280	IM B5 dSKg 160,180,315 IM 4001 dSKg 200...280		IM 3031 dSKg 160,180,315 IM 4031 dSKg 200...280	IM V3 dSKg 160,180,315 IM 4031 dSKg 200...280

\* Silniki w wykonaniu IM1011, IM2011, IM3011, IM4011 mogą być wyposażone w daszek ochronny.  
Motors in execution IM1011, IM2011, IM3011, IM4011 can be equipped with a protective cap.

**TYP ŁOŻYSK ZASTOSOWANYCH W SILNIKACH  
TYPE OF BEARINGS USED IN MOTORS**

Wielkość mechaniczna Frame	Prędkość obrotowa / Speed [obr/min]							
	3000		1500		1000		750	
	D <sup>1)</sup>	ND <sup>2)</sup>	N	ND	N	ND	N	ND
160	6309 2ZC3		6309 2ZC3		6309 2ZC3		6309 2ZC3	
180	6311 2ZC3		6311 2ZC3		6311 2ZC3		6311 2ZC3	
200	NU 312	6312 C3	NU 312	6312 C3	NU 312	6312 C3	NU 312	6312 C3
225	NU 313	6313 C3	NU 313	6313 C3	NU 313	6313 C3	NU 313	6313 C3
250	NU 315	6315 C3	NU 315	6315 C3	NU 315	6315 C3	NU 315	6315 C3
280	NU 315	6315 C3	NU 317	6317 C3	NU 317	6317 C3	NU 317	6317 C3
315	NU 315	6315 C3	NU 318	6318 C3	NU 318	6318 C3	NU 318	6318 C3
315L	6315 C3	6315 C3	22220 ESC3	6318 C3	-	-	-	-

<sup>1)</sup> Strona napędowa / Drive side

<sup>2)</sup> Strona przeciwnapędowa / Non Drive side

**DOPUSZCZALNE OBCIĄŻENIA KOŃCA WAŁU**  
**PERMISSIBLE SHAFT END LOAD**

Wielkość mechaniczna Frame	Maksymalna siła promieniowa Max radial force		Maksymalna siła osiowa / Max axial force			Masa wirnika Weight of rotor [kg]
	x=0 [N]	x=E [N]	Pozioma Horizontal [N]	Pionowa / Vertical		
				W dół / Down [N]	W górę / Up [N]	
160M2A	2000	1500	1500	1300	1800	24
160M2B	1900	1500	1500	1200	1800	27
160M4	2500	2000	2100	1800	2400	29
160M6	3000	2300	2400	2100	2700	30
160M8A	3400	2700	2700	2500	3000	26
160M8B	3300	2600	2700	2400	3000	30
160L2	1900	1500	1400	1200	1800	31
160L4	2400	1900	2100	1800	2500	35
160L6	2800	2200	2400	2000	2800	39
160L8	3200	2500	2700	2300	3100	37
180M2	2600	2200	2100	1700	2500	37
180M4	3400	2800	2900	2500	3400	45
180L4	3300	2700	2800	2400	3400	50
180L6	3800	3200	3300	2800	3900	55
180L8	4300	3500	3600	3100	4200	55
200L2A	8500	6900	2100	1600	2600	50
200L2B	8300	6800	2000	1500	2700	59
200L4	10300	8400	2600	2000	3400	73
200L6A	11700	9600	3300	2700	4200	79
200L6B	11600	9500	3300	2600	4200	89
200L8	12800	10500	3700	3000	4600	84
225S4	12600	9900	2900	2200	3700	78
225S8	15700	12300	4100	3400	5000	85
225M2	10100	8300	2200	1700	2900	63
225M4	12400	9700	2800	2100	3800	90
225M6	14000	11000	3300	2400	4400	102
225M8	15500	12200	4100	3200	5100	97
250M2	13700	10900	2800	2100	3700	90
250M4	16700	13300	3500	2600	4700	125
250M6	18800	15000	4000	2800	5600	150
250M8	20600	16400	4900	3700	6500	150
280S2	13800	11400	2800	1800	4200	127
280S4	20900	17300	4100	2800	5900	168
280S6	24100	20000	4900	3600	6500	156
280S8	26300	21800	6000	4600	7800	166
280M2	13600	11300	2800	1700	4200	137
280M4	20700	17100	4100	2500	6100	186
280M6	23900	19800	4800	3400	6700	176
280 M8	25900	21500	5300	3700	7300	192
315S2	13600	11700	2900	1500	4700	160
315S4	22500	18800	4600	2800	6900	205
315S6	25500	21300	5300	3200	8000	237
315S8	28100	23400	6600	4500	9300	237
315M2A	13500	11600	2800	1300	4700	170
315M2B	13400	11500	2700	1100	4800	186
315M4A	22400	18600	4600	2500	7000	227
315M4B	22200	18500	4400	2300	7100	245
315M6A	25400	21100	5200	3000	8000	253
315M6B	25100	20900	5000	2500	8300	289
315M8A	27900	23300	5900	3600	8700	253
315M8B	27700	23000	5600	3100	8900	289
315L2	2700	2300	2700	800	5100	216
315L4	25100	19000	3800	1400	7000	280

- Dopuszczalna siła promieniowa jest liniową funkcją X w zakresie od X=0 do X=E.  
Permissible load as a function of X is linear in the range from X=0 to X=E.
- L<sub>n</sub> – zakładana trwałość łożysk 30 000h  
L<sub>n</sub> – service life 30 000h
- Dla trwałości łożysk L<sub>n</sub> = 40 000h wartości dopuszczalnych obciążeń należy zmniejszyć o 20%  
For service life L<sub>n</sub> = 40 000h above values decrease about 20%

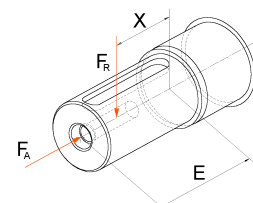

Producent zastrzega sobie możliwość zmian danych zawartych w katalogu wynikających z ciągłego doskonalenia produktów  
The manufacturer reserve the right to introduce operating parameter and dimension changes in course of modernisation