

FABRYKA MASZYN ELEKTRYCZNYCH S.A.

indukta

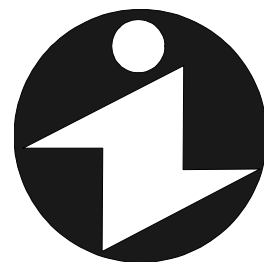

KARTA KATALOGOWA CATALOGUE CARD

Trójfazowe silniki indukcyjne
pierścieniowe dźwignicowe

Three - phase induction slip - ring
crane motors

Cantoni®
GROUP

TELEFON: [48] [33] 827-20-00 ÷ 04
FAX: [48] [33] 827-20-97 ÷ 99
e-mail: indukta@cantonimotor.com.pl
<http://www.indukta.com.pl>

Charakterystyka wykonania:

- silniki przeznaczone są do pracy przerywnej S3-25%, S3-40%, S3-60%, S3-100%;
- napięcie znamionowe 400 [V];
- częstotliwość napięcia zasilania 50 [Hz];
- temperatura otoczenia od -15 do +40[°C];
- wysokość instalowania do 1000 [m] n.p.m.;
- izolacja klasy F;
- stopień ochrony IP 44;
- z jednym czopem końcowym wału wg rysunku wymiarowego;
- z termistorowym czujnikiem temperatury w czołach uzwojenia stojana;
- skrzynka zaciskowa z dławnicami i tabliczką 6-zaciskową i 3-zaciskową.

Wykonania na życzenia:

- z dwoma walcowymi czopami wału wg rysunku wymiarowego;
- na napięcia od 380V do 690 V (690 V tylko Y)

- na częstotliwości 60 Hz, przy czym zmieniają się parametry wirnika;
- przystosowane do pracy w klimacie tropikalnym TH, TA lub MT ;
- o podwyższonym stopniu ochrony IP 55;
- fabryka wykonuje również silniki różniące się od wykonania podstawowego po uprzednim uzgodnieniu szczegółów konstrukcyjnych i terminów dostaw.

Sposób zamawiania:

- W zamówieniu należy jednoznacznie podać pełne określenie typu silnika, moc, rodzaj pracy, prędkość obrotową, napięcie zasilające, układ połączeń, częstotliwość, formę wykonania oraz inne szczegóły niekatalogowego lub specjalnego wykonania.

Features:

- rated outputs for S3 - 25%, S3- 40%, S3 - 60%, S3 - 100% type of duty;
- rated voltage 400 [V];
- frequency 50 [Hz]
- ambient temperature from -15[°C] to +40[°C];
- altitude up to 1000 [m] above sea level;
- insulation class F;
- protection degree IP 44;
- with one free shaft extension according to dimension drawing;
- with temperature - sensitive resistors in the winding ends of the stator;
- terminal box with packing glands with 6 and 3 terminals.

Features on request:

- two cylindrical shaft extension according to dimension drawing;
- for rated voltage from 380 V to 690 V (690 V only Y);
- for 60 Hz frequency where the performances of the rotor are changed;
- fit for work in tropical climate TH, TA or MT;

- protection degree IP55;
- factory produces various types of motors but constructional details and delivery time must be agreed individually.

How to order:

- In the order there must be clearly given : full designation of the motor, rated output, rated speed, rated voltage, phase connection, frequency, mounting form and all other details which are not included in the catalogue or represent a special execution.

PARAMETRY EKSPLOATACYJNE SILNIKÓW PERFORMANCES OF MOTORS

Typ silnika	Rodzaj pracy	P _n		n	η _n	cos φ _n	I _{1n} przy 400 V	m _{max}	M _n	Wirnik			k=U ₂ /√3·I ₂	J	Masa
										I ₂	U ₂	R ₂₀			
		Type of motor	Type of duty	Rated output	Rated speed	Efficiency	Power factor	Full-load amps at 400 V	Break-down torque	Torque	I ₂	U ₂	R ₂₀	k	Moment of inertia
		[kW]	[HP]	[min ⁻¹]	[%]	—	[A]	[%]	[Nm]	[A]	[V]	[Ω]	[Ω]	[kgm ²]	[kg]
2p=4 n _s =1500 obr/min; f=50 Hz — największa dopuszczalna eksploatacyjna prędkość obrotowa 3000 obr/min															
2p=4 n _s =1500 rpm; f=50 Hz — the maximum permissible rated speed of exploitation 3000 rpm															
SUDf 100 L-4A	S3-25%	1,3	1,8	1310	69,0	0,82	3,3	210	9,5	23,2	35	0,046	0,87	0,009	40
	S3-40%	1,3	1,8	1310	69,0	0,82	3,3	210	9,5	23,2			0,87		
	S3-60%	1,3	1,8	1310	69,0	0,82	3,3	210	9,5	23,2			0,87		
	S3-100%	1,1	1,5	1350	70,4	0,77	2,9	250	7,8	19,6			1,03		
SUDf 100 L-4B	S3-25%	1,7	2,3	1310	72,1	0,82	4,2	230	12,4	25,3	40	0,052	0,91	0,010	45
	S3-40%	1,7	2,3	1310	72,1	0,82	4,2	230	12,4	25,3			0,91		
	S3-60%	1,7	2,3	1310	72,1	0,82	4,2	230	12,4	25,3			0,91		
	S3-100%	1,5	2,0	1330	73,1	0,79	3,7	260	10,8	22,3			1,03		
SUDf 112 M-4A	S3-25%	3,3	4,5	1380	79,5	0,83	7,2	250	22,8	20,4	120	0,195	3,40	0,020	65
	S3-40%	3,0	4,0	1390	80,6	0,82	6,6	280	20,6	18,0			3,85		
	S3-60%	2,5	3,4	1410	81,2	0,78	5,7	340	16,9	14,4			4,81		
	S3-100%	2,2	3,0	1420	81,0	0,75	5,2	390	14,8	12,6			5,50		
SUDf 112 M-4B	S3-25%	4,4	5,9	1400	83,0	0,83	9,2	270	30,0	19,8	150	0,205	4,37	0,025	70
	S3-40%	4,0	5,5	1410	83,4	0,81	8,6	300	27,1	17,6			4,92		
	S3-60%	3,3	4,5	1430	83,7	0,77	7,4	370	22,0	14,2			6,10		
	S3-100%	3,0	4,0	1440	83,5	0,75	6,9	410	19,9	12,6			6,87		
SUDg 132 M-4A	S3-25%	7,0	9,5	1390	82,0	0,85	14,4	220	48,1	30,3	150	0,123	2,86	0,035	90
	S3-40%	6,3	8,5	1400	83,0	0,84	13,0	250	42,9	26,6			3,26		
	S3-60%	5,3	7,2	1420	83,8	0,81	11,3	300	35,6	21,9			3,95		
	S3-100%	4,8	6,5	1425	84,0	0,78	10,5	330	32,2	19,8			4,37		
SUDg 132 M-4B	S3-25%	8,3	11,3	1400	82,9	0,84	17,2	240	56,6	30,0	180	0,138	3,46	0,040	95
	S3-40%	7,5	10,0	1410	83,8	0,83	15,6	270	50,8	26,5			3,92		
	S3-60%	6,3	8,5	1425	84,7	0,80	13,4	320	42,2	22,0			4,72		
	S3-100%	5,5	7,5	1435	84,5	0,77	12,2	370	36,6	19,0			5,47		
SUDg 160 M-4	S3-25%	11,0	15,0	1410	84,2	0,84	22,4	250	74,5	41,5	175	0,087	2,43	0,077	130
	S3-40%	10,0	13,4	1420	84,5	0,83	20,6	280	67,2	37,2			2,72		
	S3-60%	8,5	11,5	1430	85,5	0,80	18,0	330	56,8	30,9			3,27		
	S3-100%	7,5	10,0	1440	85,6	0,77	16,4	380	49,7	27,3			3,70		
SUDg 160 L-4	S3-25%	16,5	22,2	1420	85,5	0,85	32,8	230	111,0	45,2	240	0,103	3,06	0,098	155
	S3-40%	14,5	19,5	1430	87,0	0,84	28,6	270	96,8	39,0			3,55		
	S3-60%	12,5	16,9	1440	87,5	0,82	25,2	310	82,9	33,8			4,10		
	S3-100%	11,0	15,0	1450	87,6	0,80	22,6	360	72,4	28,9			4,80		
SUDg 180 L-4	S3-25%	22,0	30,0	1420	85,0	0,89	42,0	240	147,9	56,7	255	0,073	2,60	0,191	205
	S3-40%	19,5	26,3	1430	86,0	0,88	37,1	270	130,2	49,3			2,99		
	S3-60%	17,0	23,0	1440	86,5	0,86	33,0	310	112,7	42,5			3,46		
	S3-100%	15,0	20,0	1445	87,3	0,84	29,5	350	99,1	37,6			3,91		
2p=6 n _s =1000 obr/min; f=50 Hz — największa dopuszczalna eksploatacyjna prędkość obrotowa 2000 obr/min															
2p=6 n _s =1000 rpm; f=50 Hz — the maximum permissible rated speed of exploitation 2000 rpm															
SUDf 100 L-6A	S3-25%	1,1	1,5	850	63,4	0,70	3,6	160	12,3	22,9	30	0,054	0,75	0,011	40
	S3-40%	1,1	1,5	850	63,4	0,70	3,6	160	12,3	22,9			0,75		
	S3-60%	0,9	1,2	890	66,5	0,65	3,0	210	9,6	18,7			0,93		
	S3-100%	0,8	1,1	905	66,9	0,61	2,9	240	8,4	16,7			1,04		
SUDf 100 L-6B	S3-25%	1,5	2,0	860	67,1	0,79	4,1	190	16,6	23,4	40	0,061	0,99	0,012	45
	S3-40%	1,5	2,0	860	67,1	0,79	4,1	190	16,6	23,4			0,99		
	S3-60%	1,3	1,8	885	69,3	0,75	3,6	230	14,0	20,3			1,14		
	S3-100%	1,1	1,5	905	70,2	0,68	3,3	280	11,6	17,2			1,34		
SUDf 112 M-6A	S3-25%	2,2	3,0	890	74,0	0,76	5,6	210	23,6	15,2	95	0,23	3,61	0,028	65
	S3-40%	2,0	2,7	910	75,0	0,73	5,2	240	21,0	13,5			4,06		
	S3-60%	1,7	2,3	925	75,5	0,69	4,7	290	17,5	11,3			4,85		
	S3-100%	1,5	2,0	930	75,5	0,65	4,4	330	15,4	9,7			5,65		

Typ silnika	Rodzaj pracy	P _n		n	η _n	cos φ _n	I _{1n} przy 400 V	m _{max}	M _n	Wirnik			k=U ₂ /√3·I ₂	J	Masa									
		Rated output								Rated speed	Efficiency	Power factor				Full-load amps at 400 V	Break-down torque	Torque	I ₂	U ₂	R _{r20}	k	Moment of inertia	Weight
		[kW]	[HP]																[min ⁻¹]	[%]	—			
SUDf 112 M-6B	S3-25%	3,3	4,5	920	77,3	0,72	8,6	250	34,2	14,6	145	0,29	5,73	0,030	70									
	S3-40%	3,0	4,0	930	77,8	0,69	8,1	280	30,8	13,0			6,44											
	S3-60%	2,5	3,4	940	78,0	0,64	7,2	340	25,4	10,8			7,75											
	S3-100%	2,2	3,0	950	77,2	0,60	6,8	390	22,1	9,4			8,90											
SUDg 132 M-6A	S3-25%	5,0	6,8	915	79,0	0,78	11,7	190	52,2	27,0	120	0,119	2,57	0,045	90									
	S3-40%	4,5	6,1	925	80,5	0,77	10,5	220	46,6	23,8			2,91											
	S3-60%	3,9	5,3	935	81,5	0,73	9,4	260	39,8	20,2			3,43											
	S3-100%	3,5	4,7	940	81,7	0,70	8,8	290	35,5	18,1			3,89											
SUDg 132 M-6B	S3-25%	6,1	8,3	935	80,2	0,75	14,6	210	62,3	25,3	145	0,132	3,31	0,051	95									
	S3-40%	5,5	7,5	940	81,0	0,73	13,4	230	55,6	22,5			3,72											
	S3-60%	4,6	6,2	950	81,6	0,68	12,0	280	46,2	18,8			4,45											
	S3-100%	4,2	5,7	955	81,6	0,66	11,2	300	42,0	17,2			4,87											
SUDg 160 M-6	S3-25%	8,0	10,8	930	82,5	0,74	18,9	200	82,1	28,6	180	0,150	3,63	0,079	130									
	S3-40%	7,0	9,5	940	83,1	0,71	17,1	230	71,1	24,6			4,22											
	S3-60%	6,0	8,1	950	83,5	0,67	15,5	270	60,3	20,8			5,00											
	S3-100%	5,5	7,5	955	83,7	0,65	14,5	300	55,0	19,1			5,44											
SUDg 160 L-6	S3-25%	11,5	15,5	930	84,3	0,77	25,6	210	118,1	31,5	250	0,180	4,58	0,105	155									
	S3-40%	10,0	13,4	940	85,2	0,76	22,3	240	101,8	26,5			5,45											
	S3-60%	8,5	11,5	950	86,0	0,73	19,6	280	85,4	22,1			6,53											
	S3-100%	7,5	10,0	955	86,4	0,69	18,1	320	75,0	19,2			7,52											
SUDg 180 L-6	S3-25%	16,5	22,2	950	85,7	0,84	33,1	220	165,9	47,0	225	0,077	2,76	0,237	205									
	S3-40%	14,5	19,5	955	86,2	0,81	29,9	250	145,0	40,0			3,21											
	S3-60%	12,5	16,9	960	86,5	0,79	26,4	290	124,3	34,8			3,73											
	S3-100%	11,0	15,0	965	86,3	0,75	24,5	320	108,9	30,3			4,29											
2p=8 n _s =750 obr/min; f=50 Hz — największa dopuszczalna eksploatacyjna prędkość obrotowa 1500 obr/min																								
2p=8 n _s =750 rpm; f=50 Hz — the maximum permissible rated speed of exploitation 1500 rpm																								
SUDg 132 M-8A	S3-25%	3,3	4,5	670	72,0	0,73	9,0	200	47,0	15,0	135	0,286	5,20	0,053	90									
	S3-40%	3,0	4,0	680	73,5	0,71	8,3	220	42,1	13,5			5,77											
	S3-60%	2,5	3,4	695	74,5	0,66	7,3	270	34,3	11,0			7,08											
	S3-100%	2,2	3,0	705	74,0	0,61	7,0	310	29,8	9,8			7,95											
SUDg 132 M-8B	S3-25%	4,5	6,1	675	74,0	0,71	12,4	190	63,7	15,3	175	0,328	6,6	0,066	95									
	S3-40%	4,0	5,5	685	75,2	0,68	11,3	220	55,8	13,5			7,48											
	S3-60%	3,5	4,7	695	75,9	0,64	10,4	250	48,1	11,5			8,78											
	S3-100%	3,0	4,0	705	75,8	0,59	9,7	300	40,6	9,6			10,52											
SUDg 160 M-8	S3-25%	6,2	8,4	675	77,1	0,76	15,3	190	87,7	25,7	160	0,205	3,59	0,098	130									
	S3-40%	5,5	7,5	685	78,6	0,74	13,7	220	76,7	21,8			4,24											
	S3-60%	4,7	6,3	695	80,2	0,71	11,9	260	64,6	18,1			5,10											
	S3-100%	4,0	5,5	705	81,0	0,66	10,8	310	54,2	14,8			6,24											
SUDg 160 L-8	S3-25%	8,0	10,8	680	78,5	0,76	19,4	190	112,3	24,7	205	0,233	4,79	0,119	150									
	S3-40%	7,0	9,5	690	80,0	0,72	17,6	220	96,9	21,0			5,64											
	S3-60%	6,0	8,1	700	81,0	0,69	15,5	260	81,8	17,4			6,80											
	S3-100%	5,2	7,0	705	81,1	0,64	14,4	300	70,4	14,7			8,05											
SUDg 180 L-8	S3-25%	11,5	15,5	705	85,0	0,75	26,0	190	155,8	34,9	215	0,123	3,55	0,235	205									
	S3-40%	10,0	13,4	715	85,6	0,72	23,4	220	133,6	30,0			4,14											
	S3-60%	8,5	11,5	720	86,2	0,69	20,6	260	112,7	25,5			4,87											
	S3-100%	7,5	10,0	725	86,2	0,65	19,3	300	98,8	22,3			5,57											

k - wartość rezystancji, którą należy włączyć w obwód każdej fazy wirnika aby przy zatrzymaniu wirnika (0 obr/min) uzyskać moment rozruchowy równy momentowi maksymalnemu silnika (M_{max}).

k - resistance value which must be switched on the circuit of each phase of the rotor in order to attain, starting torque equal to the break-down torque (M_{max}), during stopping the rotor (0 rpm).

Wymiary montażowe silników na łapach Mounting dimensions for foot-mounted motors

Typ Type	A	B	C	D,DA	E,EA	F,FA	GA,GC	H	K
	[mm]								
SUDf 100L ...	160	140	63	28j6	60	8h9	31,0	100	12
SUDf 112M ...	190	140	70	28j6	60	8h9	31,0	112	12
SUDg 132M ...	216	178	89	38k6	80	10h9	41,0	132	12
SUDg 160M ...	254	210	108	42k6	110	12h9	45,0	160	15
SUDg 160L ...	254	254	108	42k6	110	12h9	45,0	160	15
SUDg 180L ...	279	279	121	48k6	110	14h9	51,5	180	15

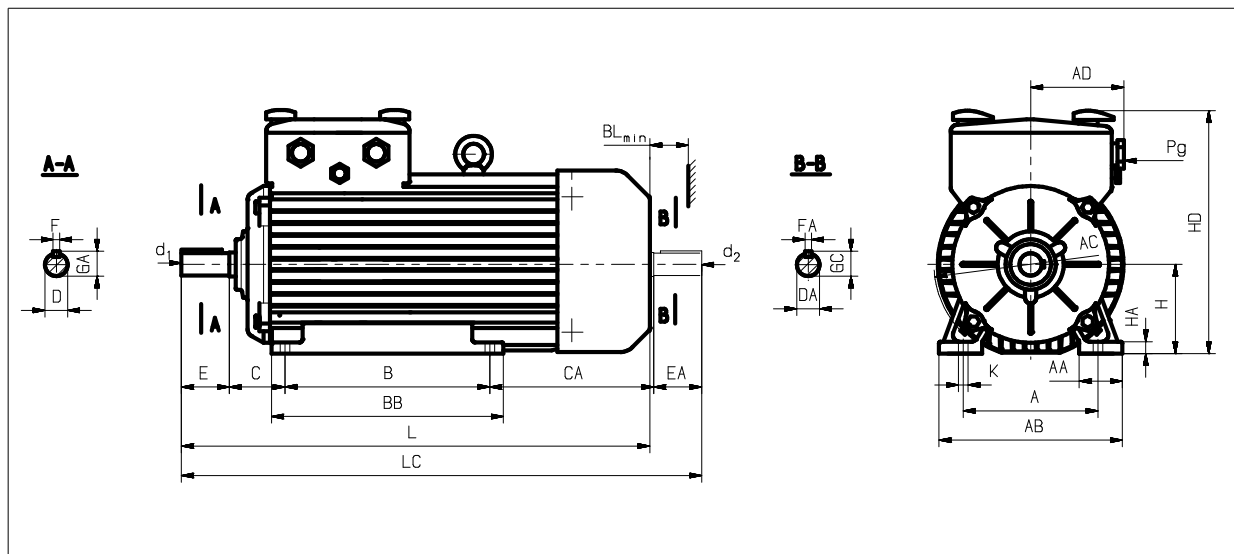

Wymiary gabarytowe silników na łapach Overall dimensions for foot-mounted motors

Typ Type	AA	AB	AC	AD	BB	BL	CA	d1,d2	HA	HD	L	LC	Pg		Łożysko nr Bearing No
	[mm]												dla klimatu umiarkowanego	dla klimatu morskiego	
													for moderate climate	for marine climate	
SUDf 100L ...	45	205	206	132	240	20	287	M10	15	277	545	610	3 x M25 x 1,5	3 x M20 x 1	6306 2Z
SUDf 112M ...	54	235	245	155	280	20	300	M10	17	307	565	630	2 x M32 x 1,5 1 x M25 x 1,5	2 x M27 x 1,5 1 x M20 x 1	6306 2Z
SUDg 132M ...	56	260	274	155	280	40	329	M12	19	338	640	756	2 x M32 x 1,5 1 x M25 x 1,5	2 x M27 x 1,5 1 x M20 x 1	6308 2Z
SUDg 160M ...	60	310	323	180	310	40	329	M16	23	385	749	867	2 x M40 x 1,5 1 x M25 x 1,5	2 x M33 x 1,5 1 x M20 x 1	6309 2Z
SUDg 160L ...	60	310	323	180	370	40	344	M16	23	385	808	926	2 x M40 x 1,5 1 x M25 x 1,5	2 x M33 x 1,5 1 x M20 x 1	6309 2Z
SUDg 180L ...	70	345	360	180	400	40	370	M16	26	430	870	990	2 x M40 x 1,5 1 x M25 x 1,5	2 x M33 x 1,5 1 x M20 x 1	6311 2Z

Formy wykonania:

- IM 1001, IM 1011, IM 1031, IM 1051, IM 1061, IM 1071 - wg IEC 34-7, PN-EN 60034-7
- IM B3, IM B6, IM B7, IM B8, IM V5, IM V6 - wg IEC 34-7, PN-EN 60034-7

Mounting forms:

- IM 1001, IM 1011, IM 1031, IM 1051, IM 1061, IM 1071 - per IEC 34-7, PN-EN 60034-7
- IM B3, IM B6, IM B7, IM B8, IM V5, IM V6 - per IEC 34-7, PN-EN 60034-7

Wymiary montażowe silników kołnierzych Mounting dimensions for flange-mounted motors

Typ Type	D,DA	E,EA	F,FA	GA,GC	M	N	P	S	T
	[mm]								
SUDKf 100L...	28j6	60	8h9	31,0	215	180j6	250	15	4
SUDKf 112M...	28j6	60	8h9	31,0	215	180j6	250	15	4
SUDKg 132M...	38k6	80	10h9	41,0	265	230j6	300	15	4
SUDKg 160M...	42k6	110	12h9	45,0	300	250j6	350	19	5
SUDKg 160L...	42k6	110	12h9	45,0	300	250j6	350	19	5
SUDKg 180L...	48k6	110	14h9	51,5	300	250j6	350	19	5

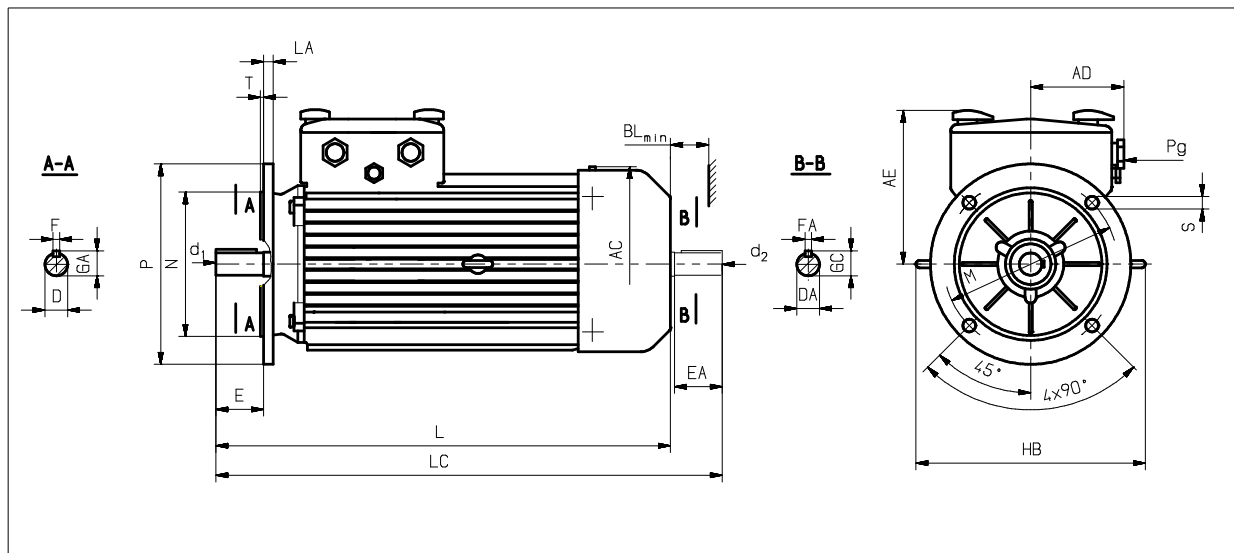

Wymiary gabarytowe silników kołnierzych Overall dimensions for flange-mounted motors

Typ Type	AC	AE	BL	HB	d1,d2	L	LA	LC	Pg		Łożysko nr Bearing No
	[mm]								dla klimatu umiarkowanego	dla klimatu morskiego	
									for moderate climate	for marine climate	
SUDKf 100L...	206	177	20	275	M10	545	11	610	3 x M25 x 1,5	3 x M20 x 1	6306 2Z
SUDKf 112M...	245	195	20	325	M10	565	12	630	2 x M32 x 1,5 1 x M25 x 1,5	2 x M27 x 1,5 1 x M20 x 1	6306 2Z
SUDKg 132M...	274	205	40	360	M12	640	12	756	2 x M32 x 1,5 1 x M25 x 1,5	2 x M27 x 1,5 1 x M20 x 1	6308 2Z
SUDKg 160M...	323	225	40	415	M16	749	13	867	2 x M40 x 1,5 1 x M25 x 1,5	2 x M33 x 1,5 1 x M20 x 1	6309 2Z
SUDKg 160L...	323	225	40	415	M16	808	13	926	2 x M40 x 1,5 1 x M25 x 1,5	2 x M33 x 1,5 1 x M20 x 1	6309 2Z
SUDKg 180L...	360	250	40	485	M16	870	13	990	2 x M40 x 1,5 1 x M25 x 1,5	2 x M33 x 1,5 1 x M20 x 1	6311 2Z

Formy wykonania:

- IM 3001, IM 3011, IM 3031 - wg IEC 34-7, PN-EN 60034-7
- IM B5, IM V1, IM V3 - wg IEC 34-7, PN-EN 60034-7

Mounting forms:

- IM 3001, IM 3011, IM 3031 - per IEC 34-7, PN-EN 60034-7
- IM B5, IM V1, IM V3 - per IEC 34-7, PN-EN 60034-7

Wymiary montażowe silników kołnierzowych na łapach Mounting dimensions for foot-flange-mounted motors

Typ Type	A	B	C	D,DA	E,EA	F,FA	GA,GC	H	K	M	N	P	S	T
	[mm]													
SUDLf 100L...	160	140	63	28j6	60	8h9	31,0	100	12	215	180j6	250	15	4
SUDLf 112M...	190	140	70	28j6	60	8h9	31,0	112	12	215	180j6	250	15	4
SUDLg 132M...	216	178	89	38k6	80	10h9	41,0	132	12	265	230j6	300	15	4
SUDLg 160M...	254	210	108	42k6	110	12h9	45,0	160	15	300	250j6	350	19	5
SUDLg 160L...	254	254	108	42k6	110	12h9	45,0	160	15	300	250j6	350	19	5
SUDLg 180L...	279	279	121	48k6	110	14h9	51,5	180	15	300	250j6	350	19	5

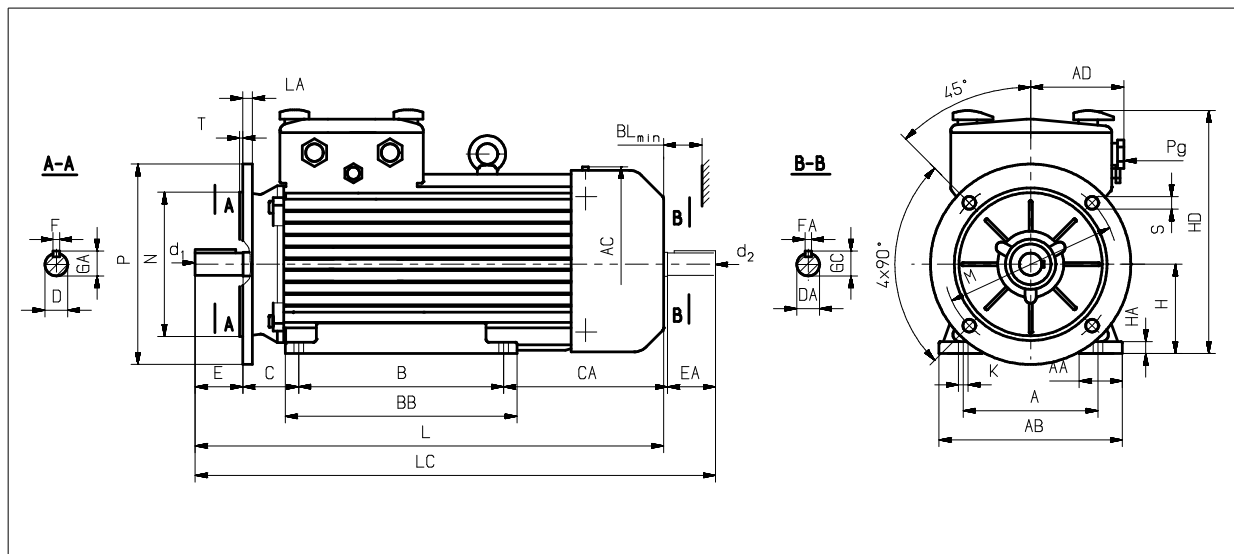

Wymiary gabarytowe silników kołnierzowych na łapach Overall dimensions for foot-flange-mounted motors

Typ Type	AA	AB	AC	AD	BB	BL	CA	d1,d2	HA	HD	L	LA	LC	Pg		Łożysko nr Bearing No
	[mm]													dla klimatu umiarkowanego	dla klimatu morskiego	
														for moderate climate	for marine climate	
SUDLf 100L...	45	205	206	132	240	20	287	M10	15	277	545	11	610	3 x M25 x 1,5	3 x M20 x 1	6306 2Z
SUDLf 112M...	54	235	245	155	280	20	300	M10	17	307	565	12	630	2 x M32 x 1,5 1 x M25 x 1,5	2 x M27 x 1,5 1 x M20 x 1	6306 2Z
SUDLg 132M...	56	260	274	155	280	40	329	M12	19	338	640	12	756	2 x M32 x 1,5 1 x M25 x 1,5	2 x M27 x 1,5 1 x M20 x 1	6308 2Z
SUDLg 160M...	60	310	323	180	310	40	329	M16	23	385	749	13	867	2 x M40 x 1,5 1 x M25 x 1,5	2 x M33 x 1,5 1 x M20 x 1	6309 2Z
SUDLg 160L...	60	310	323	180	370	40	344	M16	23	385	808	13	926	2 x M40 x 1,5 1 x M25 x 1,5	2 x M33 x 1,5 1 x M20 x 1	6309 2Z
SUDLg 180L...	70	345	360	180	400	40	370	M16	26	430	870	13	990	2 x M40 x 1,5 1 x M25 x 1,5	2 x M33 x 1,5 1 x M20 x 1	6311 2Z

Formy wykonania:

- IM 2001, IM 2011, IM 2031 - wg IEC 34-7, PN-EN 60034-7
- IM B35, IM V15, IM V36 - wg IEC 34-7, PN-EN 60034-7

Mounting forms:

- IM 2001, IM 2011, IM 2031 - per IEC 34-7, PN-EN 60034-7
- IM B35, IM V15, IM V36 - per IEC 34-7, PN-EN 60034-7